

# Product Manual

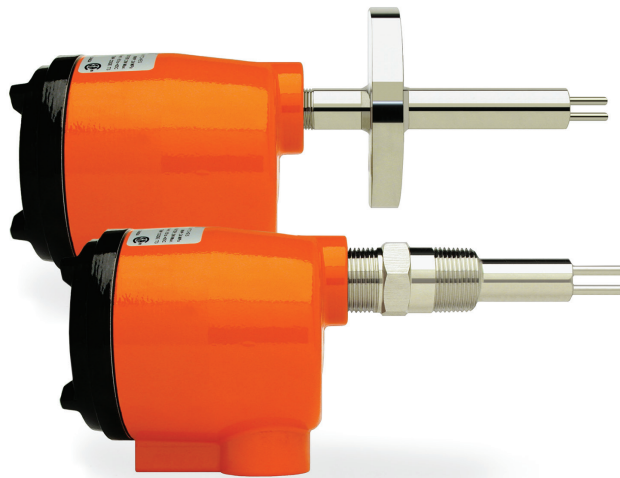

# CLASSIC™ Series

Thermal Flow, Level, Interface &  
Temperature Switches & Transmitters



CRN  
Canadian  
Registration  
Number



**KAYDEN**®  
Helping the World Switch™

# **KAYDEN**<sup>®</sup>

## **Helping the World Switch**<sup>™</sup>

### **NOTICE**

Read this manual before working with the product. For personal and system safety, and for optimum product performance, make sure you thoroughly understand the contents before installing, using or maintaining this product.

For equipment service or support needs, please contact your local representative.

### **CAUTION**

The products described in this document are NOT designed for nuclear qualified applications.

# Table of Contents

## 1. INTRODUCTION

CLASSIC™ 800 Specifications.....	iv
Overview of Switch Transmitter Setup.....	vi
Models Described in This Manual.....	1
CLASSIC™ 800 Electronics.....	2
Typical Applications.....	2
I. THE KAYDEN CLASSIC 800 - DIGITAL ELECTRONICS FEATURES.....	3
II. PRINCIPLE OF OPERATION.....	4
III. THERMAL SIGNAL.....	5
IV. 4-20 mA ANALOG OUTPUT.....	6

## 2. INSTALLATION GUIDELINES

I. GENERAL.....	7
II. APPLICATION CONSIDERATIONS.....	8
Application Considerations - Flow.....	8
Application Principles - Flow, Level, Interface & Temperature.....	8
Application Considerations - Level.....	9
Application Considerations - Interface.....	9
III. GUIDELINES FOR PIPE MOUNTING.....	10
Horizontal Pipe - Side Mount (Ideal).....	10
Horizontal Pipe - Top Mount.....	10
Horizontal Pipe - Bottom Mount.....	10
Vertical Pipe - Side Mount (Acceptable).....	11
Vertical Pipe - Side Mount - Downward Flow.....	11
Vertical Pipe - Top & Bottom Mount (Less Desirable).....	11
IV. INSTALLING THE SENSOR.....	12
V. ELECTRICAL.....	13
Wiring Connection Diagram.....	15
VI. TESTING THE INSTALLATION.....	16

## 3. SETUP & OPERATION

Display Panel Indicators.....	17
Display Panel Button Functions.....	17
I. GENERAL INFORMATION.....	18
II. CONTROL SETTINGS and SETUP PROCEDURES.....	18
1. View or Adjust Relay 1 & 2 Energized Mode.....	19
Failsafe Relay Configurations.....	20
2. View or Adjust the 4–20 mA Fault Mode Configuration.....	21
3. View or Adjust Set Points 1 & 2.....	22
4. View or Adjust the Start-up Bypass Timer.....	23
5. View or Adjust the Heater Power.....	24
6. View or Adjust the Node Address & View the Software Revision.....	25
7. View or Adjust the 4-20 mA Output Configuration (Forward or Reverse).....	26
8. View or Adjust the 0% & 100% Thermal Signal Scaled Bar Graph View.....	27

9. View or Adjust the 0% & 100% Thermal Signal LEDs: .....	28
Kayden RCM Software .....	29
RS-485 Remote Communications.....	30
Converters / Adapters - USB to RS-232 & RS-232 to RS-485 .....	30
Communication Cable .....	30
<b>4. QUICK SETUP GUIDE</b>	
Mechanical Installation .....	31
Sensor Orientation .....	31
Setup & Configuration Flow Chart .....	31
Display Panel Indicators .....	31
Display Panel Button Functions .....	31
Power AC/DC .....	31
Relay Outputs .....	31
Heater Power .....	31
<b>5. MAINTENANCE</b>	
1. Cover.....	35
2. Process and Conduit Connections.....	35
3. Sensing Elements.....	35
4. Electronics Module .....	35
5. Adjustment & Calibration .....	35
6. Preventative Maintenance Requirements.....	35
<b>6. BINARY TABLE.....</b>	<b>38</b>
LED Fault Indicator .....	39
<b>7. TROUBLESHOOTING</b>	
How to Reset the CLASSIC Factory Settings .....	40
Resistance Values for Sensor Wiring.....	41
Return of Material .....	42
Hazardous Materials.....	42
Service, Technical Support & Contact Information.....	42
<b>8. GLOSSARY.....</b>	<b>43</b>
<b>APPENDIX A - OUTLINE DIMENSIONAL DRAWING</b>	
CLASSIC™ 810 Threaded.....	44
CLASSIC™ 812 Flanged.....	44
CLASSIC™ 828 Sanitary Flanged .....	44
CLASSIC™ 830 InLine Threaded (Horizontal).....	45
CLASSIC™ 830 InLine Threaded (Vertical).....	45
CLASSIC™ 832 InLine Flanged (Horizontal) .....	46
CLASSIC™ 832 InLine Flanged (Vertical) .....	46
CLASSIC™ 816 Retractable Packing Gland Threaded - 1" MNPT – to 50 psi .....	46
CLASSIC™ 816 Retractable Packing Gland Threaded - 1" MNPT – c/w Chain – to 125 psi .....	47
CLASSIC™ 816 Retractable Packing Gland Threaded - 1" MNPT – to 500 psi.....	47
CLASSIC™ 814 Retractable Packing Gland Flanged - to 50 psi.....	47
CLASSIC™ 814 Retractable Packing Gland Threaded - to 125 psi.....	48



Remote Electronics Enclosure - Flameproof (CSA) ..... 48  
 Remote Electronics Enclosure - Flameproof (FM) ..... 49

**APPENDIX B - MODEL NUMBER LEGENDS**

**ORDER LEGENDS**

CLASSIC™ 810 Threaded..... 51  
 CLASSIC™ 812 Flanged..... 52  
 CLASSIC™ 830 InLine Threaded ..... 53  
 CLASSIC™ 832 InLine Flanged ..... 54  
 CLASSIC™ 816 Threaded Retractable Packing Gland ..... 55  
 CLASSIC™ 814 Flanged Retractable Packing Gland..... 56  
 CLASSIC™ 828 Sanitary Flanged ..... 57

**APPENDIX C - KAYDEN.COM WEB SITE ..... 59**

**CONTACT US & ORDERING INFORMATION ..... 63**

**TABLE OF FIGURES**

Figure 1 - CLASSIC 800 Display Panel..... 2  
 Figure 2 - How Thermal Conductivity is Displayed ..... 5  
 Figure 3 - 4-20 mA Wiring ..... 6  
 Figure 3a - Pump Flow Detection ..... 7  
 Figure 4 - Threadolet..... 10  
 Figure 6a - Horizontal Pipe, Side Mounting..... 10  
 Figure 5 - Insertion 'U' Length..... 10  
 Figure 6b - Horizontal Pipe, Top / Bottom Mounting ..... 10  
 Figure 8 - Vertical Pipe, Flow Up & Down ..... 11  
 Figure 7 - Horizontal Pipe, Sensor Positioning..... 11  
 Figure 9 - Sensor Orientation for Horizontal Flow & Level ..... 12  
 Figure 10 - Disconnecting Sensor Connector from the Electronics Module ..... 14  
 Figure 11 - CLASSIC 800 Mounting Base Plate / Wiring Terminal ..... 14  
 Figure 12 - CLASSIC 800 Wiring Connection Diagram ..... 15  
 Figure 1 - CLASSIC 800 Display Panel..... 17  
 Figure 14 - Control Functions RUN/SET Mode ..... 17  
 Figure 15 - Relay Energized Mode ..... 19  
 Figure 16 - 4-20 mA Fault Mode Configuration..... 21  
 Figure 17 - Set Point 1 & 2 Configuration ..... 22  
 Figure 18 - Start-up Bypass Timer..... 23  
 Figure 19 - Setting the Heater Power ..... 24  
 Figure 20 - Software Revision & Node (Unit) Number..... 25  
 Figure 21 - 4-20 mA & 20-4 mA Output Mode..... 26  
 Figure 22 - Scaled Bar Graph View vs. Baseline Bar Graph View ..... 27  
 Figure 23 - Setting the 0% & 100% Thermal Signal..... 28  
 Figure 24 - Factory Reset ..... 40  
 Figure 25 - Display Panel Indicators..... 41

## CLASSIC™ 800 Specifications

### Applications:

- Flow, Level, Interface & Temperature

### Process Connections:

- 1/2", 3/4", 1", 1-1/4", 1-1/2" & 2" MNPT
- 3/4" FNPT & Flanged InLine
- Flanged & Sanitary 1" to 3.5" Tri-Clamp®
- Threaded (1" MNPT) & Flanged Retractable Packing Glands

### Insertion 'U' Lengths:

- **Imperial:**  
1.2", 2", 3", 4", 6", 9", 12" & 18" standard  
Model 828 (Sanitary) - 2", 3", 4" & 6" only
- **Metric:**  
3, 5, 7.5, 10, 15, 23, 30 & 45 cm standard  
Model 828 (Sanitary) - 5, 7.5, 10 & 15 cm only
- **Custom Lengths:**  
Available in 1/2" or 1 cm increments  
Min. 1.2" - Max. 120" (3.0 - 305 cm) model dependant

### Wetted Materials:

- 316/316L Stainless Steel - standard
- Titanium Gr. 2, Hastelloy® C-276
- 316/316L Stainless Steel c/w Nickel Braze (830 & 832 InLine Models)
- Highly Saturated Nitrile (Pressure Seal - 814 & 816 Packing Gland Models)

### Enclosure Material:

- Copper-free Aluminum (does not exceed 0.4% copper)
- Powder Coated Polyester TGIC (polyester triglycidyl isocyanurate)
- NEMA 4 / Type 4 / IP55
- 1" FNPT Conduit Connection
- Buna O-ring on Cover

### Temperature Range – Continuous Service:

- **Sensors:**  
-45°C to +200°C (-50°F to +392°F)  
(Models 814 & 816: -45°C to +160°C [-50°F to +320°F])

### Electronics:

-55°C to +65°C (-67°F to +149°F)

**Note:** For temperatures above +65°C (+149°F) electronics must be remotely mounted.

### Storage:

Product should be stored in a clean and dry environment between -30° and 60° C (-34.5° and 140° F)

### Operating Pressure - Sensor:

#### Threaded Style:

- Maximum Working Pressure: 24 MPa (3500 psig) dependent on model and material of construction

#### Flanged Style:

- Maximum Working Pressure: per flange rating

#### Sanitary Tri-Clamp® Style:

- Maximum Working Pressure: per flange rating

### Switch / Transmitter Switch Point Range

#### (Insertion Style - 1/2" to 2" MNPT, Flanged):

- **Water-based Liquids:**  
0.01 to 3.0 ft./sec. (0.003 to 0.9 meters/sec.)
- **Hydrocarbon-based Liquids:**  
0.01 to 5.0 ft./sec. (0.003 to 1.5 meters/sec.)
- **Gases:**  
0.25 to 254 sfps (0.076 to 77 smps)  
Standard conditions: 21°C (70°F) at 14.7 psi (1 atm)

### Switch / Transmitter Switch Point Range

#### (InLine Style):

- **Water-based Liquids:**  
0.015 to 50 cc/sec.
- **Hydrocarbon-based Liquids:**  
0.033 to 110 cc/sec.
- **Gases:**  
0.6 to 20,000 cc/sec.  
Standard conditions: 21°C (70°F) at 14.7 psi (1 atm)

### Accuracy:

- **Flow Service:**  
±1% set point velocity over operating range of ±28°C (±50°F)
- **Level Service:**  
±0.25 inches (±0.64 cm)

## CLASSIC™ 800 Specifications

### Response Time:

- Approximately 0.5 to 30 seconds

### Remote Electronics Option:

- Maximum recommended cable length - 200 feet (60 m)
- Cable type - 24 AWG minimum - twisted pairs

### Heater Power:

- Field adjustable to optimize performance

### Input Power:

- Universal Power standard  
12-24 VDC and 115-230 VAC, 50-60 Hz
- Consumption: Maximum: 6.0 watts (fully configured)

### Outputs:

- 4-20 mA current loop
- Two (2) independent SPDT sealed relay contacts rated @ 4 amps resistive 230 VAC or 30 VDC Max.; individually adjustable

### Start-Up Bypass Timer:

- Adjustable for 0 to 100 seconds

### Communications:

- Modbus via RS-485

### RCMS (Remote Control & Monitoring Software) Functions and Features:

- Display Panel Lock-Out
- Set Points configuration<sup>1</sup>
- Relay Actuation Delay Timer
  - Independently configurable for both On and Off, increasing or decreasing
  - Adjustable from 0 - 5,000 seconds
- Start-up Bypass Timer<sup>1</sup>
  - Adjustable from 0 - 100 seconds
- Relay Mode Configuration<sup>1</sup>
  - Energized above or below set point
- Relay Temperature Mode Configuration
- Heater Power setting<sup>1</sup>
- Zero and Span settings<sup>1</sup>
- Analog (4-20 mA) output configuration<sup>1</sup>
- View and Print Graphing (Trend) function

- Configuring settings; write to device, save to file and print

- Fault Event Log

**Note:**<sup>1</sup> Also configurable from Display Panel

### Diagnostics:

- Primary watchdog circuit monitors microprocessor parameter anomalies
- Secondary watchdog circuit monitors microprocessor health
- Heater monitored for out-of-range conditions
- Fault Mode de-energizes relay(s) and halts power to the heater

### Agency Approvals:

- **CSA - ANSI/UL**  
Class I, Div. 1, Groups B, C and D;  
Ex d IIB + H2; AEx d IIB+H2  
(Class I, Zone 1, Group IIB + H2,) T3; Enclosure Type 4 / IP55



- **Single Seal Approval**  
Per ANSI/ISA 12.27.01-2003

- **CRN**  
Canadian Registration Number



**Note:** CRN approvals available.  
Visit [kayden.com](http://kayden.com) for CRN information per model and jurisdiction.

- **FM Approvals**  
Class I, Div. 1, Groups B, C and D;  
Class I, Zone 1, AEx d IIB+H2  
T2D (Ta=75°C); T3 (Ta=65°C);  
Enclosure Type 4 / IP55



### Weights and Dimensions:

- 810 Threaded: 2" U length - 7 lbs (3.18 kg)
- Carton Size - 15" x 5" x 6" (38 cm x 13 cm x 15 cm)
- Other models/sizes - consult Kayden

### Warranty:

- One (1) Year from shipment date from factory (see Terms & Conditions on [kayden.com](http://kayden.com) for details)

**Overview of Switch Setup**

**1. Warm-up**

At initial start-up or restart allow approximately 90 seconds for the heater element to warm-up and the switch to stabilize before making any adjustments.

**2. Primary Settings**

The following are the basic configurations for the CLASSIC 800 Series Electronics Modules:

- 1. Relay 1
- 2. Relay 2
- 3. Set Point 1
- 4. Set Point 2
- 5. Heater Power
- 6. 0% & 100% Thermal Signal

**3. Secondary Settings**

The following are the additional configurations:

- 1. 4-20 mA Fault Configuration
- 2. Startup Bypass Timer
- 3. Node Address & Software Revision
- 4. 4-20 mA Configuration

**Notes**

---

---

---

---

---

---

---

---

---

---

---

---

---

---

---

---

---

---

---

---

---

---

---

---

## 1

## Introduction

### Models Described In this Manual

This manual describes the following CLASSIC 800 Series Switches and Transmitters:



#### CLASSIC 810 Threaded

- Insertion Style - 1/2", 3/4", 1", 1-1/4", 1-1/2" & 2" MNPT



#### CLASSIC 812 Flanged

- Insertion Style - 1" ANSI 150 through 10" ANSI 900 Flanges



#### CLASSIC 814 Flanged Retractable Packing Gland

- Insertion Style - 1-1/2" through 10" ANSI 150 Flanges

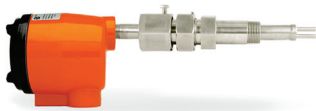

#### CLASSIC 816 Threaded Retractable Packing Gland

- Insertion Style - 1" MNPT



#### CLASSIC 828 Sanitary Flanged

- Insertion Style - 1", 1.5", 2", 2.5" & 3" Tri-Clamp® Flanges



#### CLASSIC 830 Threaded

- InLine Style - 3/4" FNPT

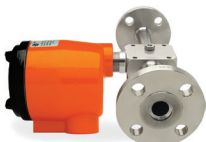

#### CLASSIC 832 Flanged

- InLine Style - 3/4" ANSI 150 through 10" ANSI 900 Flanges

**CLASSIC™ 800 Electronics**

**Display Panel & Intelligent User Interface**

The Kayden CLASSIC 800 Electronics Module is designed to be easy to install and adjust while displaying several control functions. All Kayden CLASSIC 800 Electronics Modules feature:

- Universal Power Input
- Continuous Self-test diagnostics with Fault Indicator
- Easy setup; no jumpers or trim pots
- Incrementally adjustable heater power, range and relay set points.
- All CLASSIC 800 series switches/transmitters use the same Electronics Module making it a universal spare part. The Electronics Module is easily installed in the field without returning the entire switch/transmitter to the factory.
- 4-20 mA Analog Output
- Start-up Bypass Timer
- True Temperature Compensation



**Figure 1 - CLASSIC 800 Display Panel**

**Display Panel Indicators:**

- Relay 1** On steady when Relay 1 is energized
- Relay 2** On steady when Relay 2 is energized
- Fault** Indicates a self-test error or fault condition
- Set Point 1** On steady when viewing Set Point 1
- Set Point 2** On steady when viewing Set Point 2
- Run Mode** Flashing when switch is operating
- Bypass** Flashing when the Start-up Bypass Timer is active
- Thermal Signal** Displays Thermal Signal

**The Thermal Signal increases as:**

- Flow** The flow rate increases
- Level** The sensor is submerged
- Interface** The sensor is submerged by the second liquid of greater thermal conductivity

**Typical Applications**

- Pump Protection - Dry Alarm
- Leak Detection
- Flow Monitoring & Verification
- Tank Overflow Protection
- Flare Gas Monitoring
- Monitoring Purge Air Flow
- Drain Line Flow
- Interface Control in Separation Vessels
- High Pressure Flows
- Lube Oil Systems
- Vent Monitoring
- Natural Gas to Boilers
- Emergency Eye Wash Stations
- Tanker Loading & Unloading
- Relief Valve & Rupture Disk Flow Monitoring
- Remote Indication of Flow via Analog Output & Digital Communications
- Liquids, Air & Gases
- Slurries
- Interface Detection
- Corrosive Liquids
- Hazardous & General-Purpose Areas
- Interface Control & Level Detection in Settling Vessels
- Chemical Injection/Additive Flow Monitoring

## I. THE KAYDEN CLASSIC 800 - DIGITAL ELECTRONICS FEATURES

The CLASSIC 800 is versatile, rugged, cost effective and easy to use. All setup and adjustments may be performed using the Display Panel buttons. The CLASSIC 800's Display Panel displays process condition (flow, level & interface) via the Thermal Signal Bar Graph as well as Relay state, Timer functions and operating conditions via individual LEDs. The CLASSIC 800 may also be remotely controlled and/or monitored via RS-485 using the Kayden RCM (Remote Control & Monitoring) Software and the Serial Communication Adapter (SCA) and communication cable.

Kayden's CLASSIC 800 series uses an advanced microprocessor to perform continuous **self-test diagnostics** on the Electronics Module and the sensor elements.

- Any open or shorted connection will result in an error indication that also opens all output contacts and disables the heater circuitry.
- An internal watchdog circuit ensures that the microprocessor code is performing as expected and a secondary external watchdog circuit ensures that the microprocessor itself is functioning. Both circuits force the contacts open, illuminate the Fault LED, turn the heater off and de-energize the relays in the event of a malfunction. This prevents the heater running out-of-control that could result in excessive temperatures on the probe or a burnt-out heater.
- The microprocessor also monitors the heater for out-of-range conditions. For example in a level application when the sensor is "dry" for an extended period of time, the heater will cycle between its current setting and a lower power rating until such time as the sensor is again submerged.

## II. PRINCIPLE OF OPERATION

Kayden sensors incorporate two thin-film platinum Resistance Temperature Detectors (RTDs) and a separate heater element. The Reference RTD senses the actual process condition (as temperature). Heat is applied to the Active RTD by the heater element which is controlled by the microprocessor.

The microprocessor makes continuous comparisons between the temperature readings from the Reference RTD and the Active RTD (values stored as a result of setup programming). As process conditions change, for example increased velocity in a flow application, the Reference RTD “senses” the change and the microprocessor adjusts the heater and changes the relay state if required.

The CLASSIC 800 can be setup with a narrow range to detect very low flows or very small changes in the process, or with a wider range to ignore small fluctuations. The CLASSIC 800 series switches and transmitters are digital devices and will not require calibration. By design they cannot drift or change in any way unless they suffer physical damage. After correct setup, the CLASSIC 800 will be stable and repeatable under stable process conditions.

The CLASSIC 800 may be setup in the field by the user for flow, level or interface with air, gases, liquids or slurries. The CLASSIC 800 may be setup to display process temperature through the RCM Software while functioning as a flow, level or interface switch/transmitter.

**Flow / No Flow** - When the velocity of the process media is low or nonexistent, less thermal energy (heat) is dissipated from the heated sensor. As the velocity increases the amount of energy dissipated by the process media increases, thereby increasing the Thermal Signal.

**The Thermal Signal is smallest (left-most LED illuminated) in a no-flow state and increases (LED moves to the right) as flow increases (see Figure 2).**

**Liquid Level** - Air and other gases do not dissipate heat as well as liquids. Therefore, the Thermal Signal is smallest when in a process that does not dissipate heat well (air dissipates heat slower than water).

**The Thermal Signal is smallest (left-most LED illuminated) in a dry, motionless state and increases as the fluid covers the sensor (see Figure 2).**

**Liquid Level / Interface** - The CLASSIC 800 can be setup to detect the difference between most liquids if there is very little or no velocity and each material has a unique thermal property (for example oil and water in a knockout tank).



### III. THERMAL SIGNAL

The CLASSIC 800 senses changes to the temperature differential as changes occur in the process. The “value” being sensed and displayed as the Thermal Signal is the rate of thermal dispersion. Assuming the added energy from the heater is a constant, the formula that determines the Thermal Signal has only two variables:

- 1) The thermal conductivity of the process media, and
- 2) The velocity of the process media past the sensor.

The relationship between Thermal Signal and velocity is non-linear. When one of these variables is constant in a given application, the value of the other variable can be monitored by the CLASSIC. The Thermal Signal Bar Graph displays Flow & Level as a percentage of the switch/transmitter’s full scale capability.

Figure 2 below illustrates the **Thermal Signal** LED indicators moving to the right as process velocity increases. Assuming a constant heater power and a consistent process media, as the velocity of the process increases so does the **Thermal Signal**, represented by movement of the illuminated LED to the right.

For example, if the left-most LED is illuminated on the **Thermal Signal Bar Graph**, then a minimum amount of heat is being carried away by the process based on the current settings. If the right-most LED is illuminated on the **Thermal Signal Bar Graph** this indicates the maximum amount of heat is being carried away by the process based on the current settings.

#### No Flow or Dry (Level)

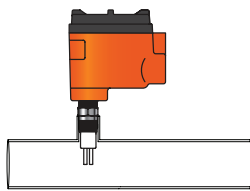

- No flow or flow is minimal

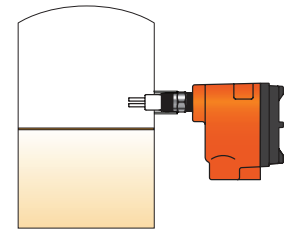
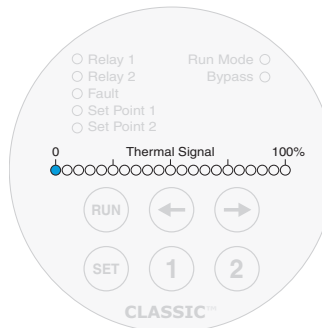

- Level of process is below sensor

#### Increasing Flow

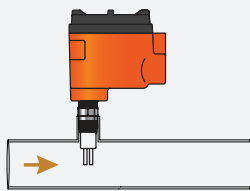

- Flow is increasing

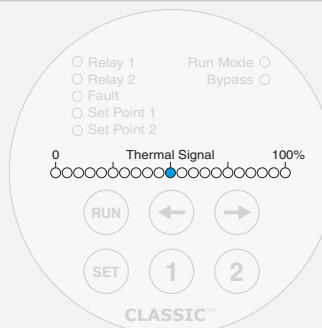

#### Maximum Flow or Wet (Level)

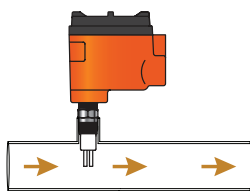

- Flow is at maximum velocity

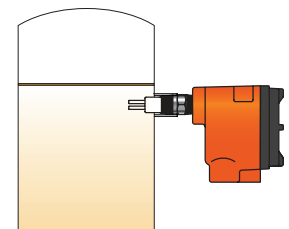
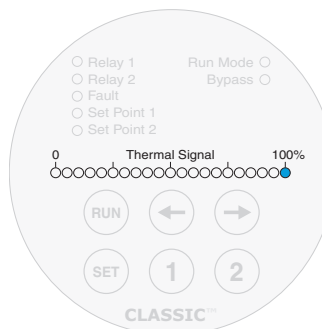

- Level of process is above sensor

Figure 2 - How Thermal Conductivity is Displayed

### IV. 4-20 mA ANALOG OUTPUT

The 4 to 20 mA analog output signal is relative to the Thermal Signal displayed on the Thermal Signal Bar Graph. The 0% to 100% of Thermal Signal corresponds to 4-20 mA or 20-4 mA. **Refer to View or Adjust the 4-20 mA Output** for programming this option.

- The 4-20 mA output signal corresponds to the scaled Thermal Signal view as determined by the range (LED-0 and LED-100 pointers).
- The 4-20 mA signal may be displayed either as forward-acting (ascending 4-20 mA) or reverse-acting (descending 20-4 mA).
- To view or adjust the 4-20 mA output current configuration: (refer to the **Section 3, “View or Adjust the 4-20 mA Output Configuration (Forward or Reverse)”** or the **“Classic 800 Series Quick Setup Guide”**)

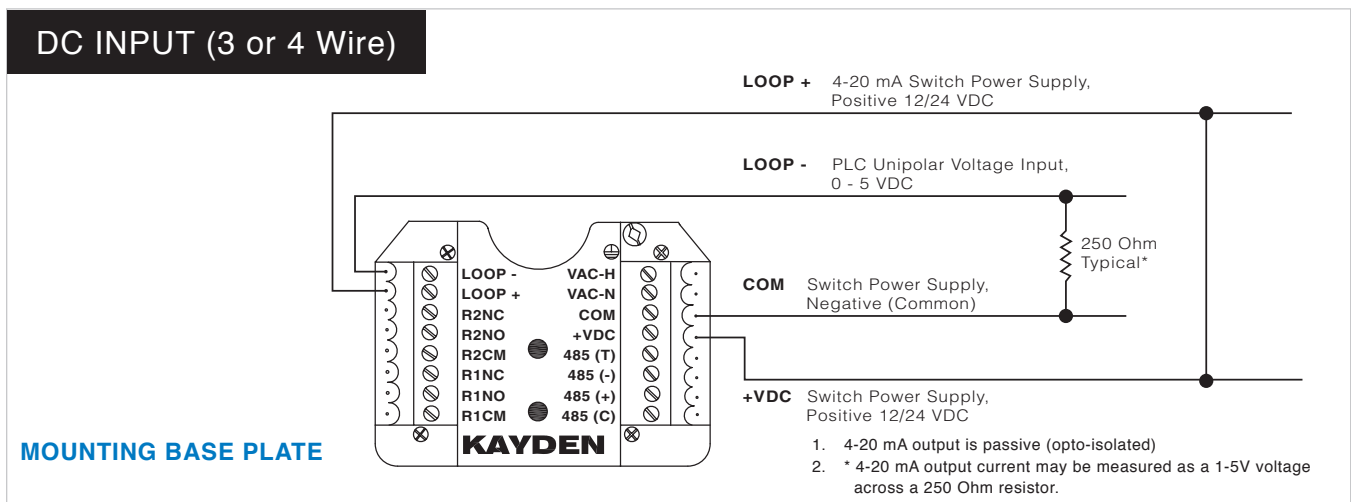
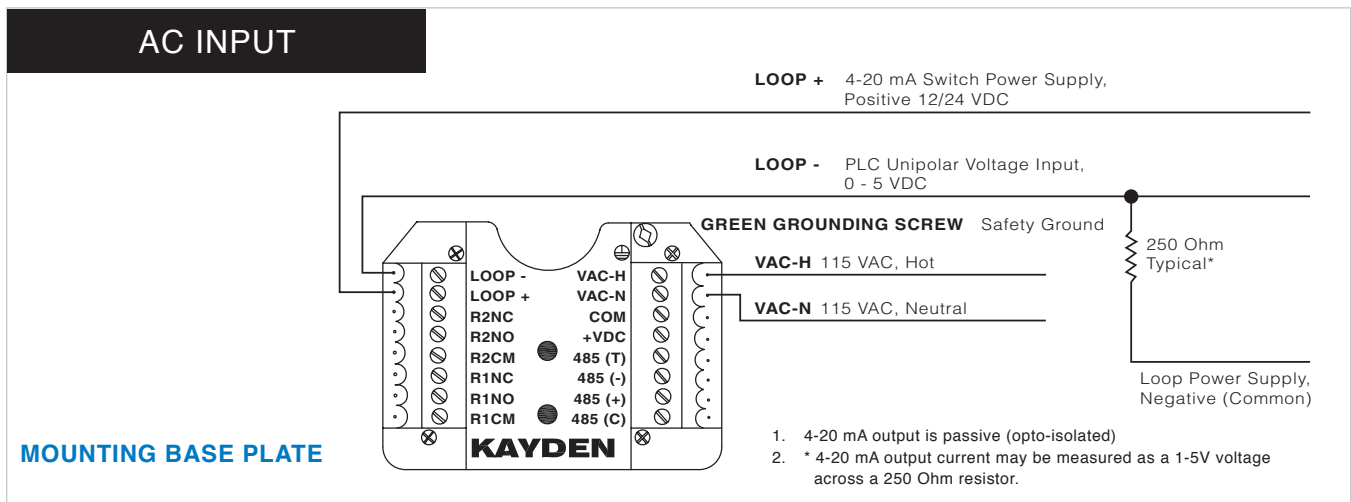

**Figure 3 - 4-20 mA Wiring**

## 2

## Installation Guidelines

## I. GENERAL

Kayden electronics are designed to be universal for flow, level, interface and temperature applications and with most liquids, gases and slurries. The user can take advantage of this flexibility through:

- Correct setup of the electronics and
- Proper physical installation of the sensor.

**Location:**

- Consider the need for easy access in order to view the operation and make any required field adjustments.
- Provide at least 12 inches (30 cm) clearance if possible to allow access for setup and viewing after installation.

**Shock and Vibration:**

- Install the switch/transmitter so as to minimize any effects due to vibration, shock and extreme temperatures.

**Temperature:**

- The continuous operating temperature limits of the Electronics Module is -55°C to +65°C (-67°F to +149°F). Ambient temperatures in excess of +65°C (+149°F) require the electronics to be mounted remotely from the sensor. Consult kayden.com or the factory for more information.
- The continuous operating temperature limits of the sensors are -45°C to +200°C (-50°F to +392°F).

**Turbulence / Interference:**

- Pumps, fans, valves, or pipe bends of 90° or more will cause turbulence or significant variance in the flow which will affect the repeatability of the switch/transmitter. Care should be taken to minimize this possibility.
- For Pump Flow/No-Flow detection the best/preferred installation point is on the inlet side of the pump. The discharge side will have turbulence, reverse flow and an undeveloped flow profile. These factors will greatly reduce repeatability and accuracy.
- Keep the sensor away from any devices that may cause physical damage such as: agitators, valves, injectors, etc.

**Note:** Many times, especially when replacing a different type of instrument, the installation point is predetermined and is difficult to change. Kayden switches/transmitters have specific design features that allow them to perform well even in difficult locations and applications. Please consult your local representative or Kayden for questions or installation / setup recommendations.

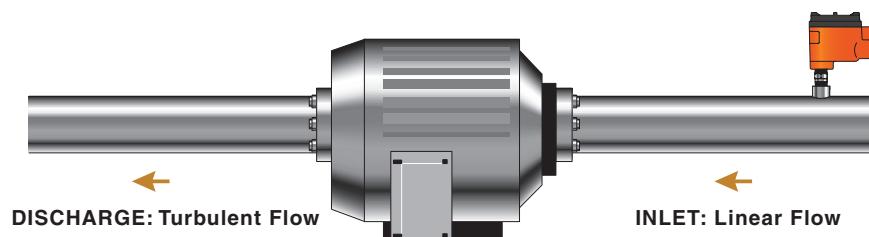

Figure 3a - Pump Flow Detection

**Application Considerations - Flow**

**Flow**

**Ideal Process Conditions**

**Liquids:**

- Consistent process composition & temperature
- Sufficient straight run flow profile (minimizes turbulence)
- Recommended minimum of 5 pipe diameters from any disturbance

**Air & Gas:**

- Consistent process composition & temperature
- Sufficient straight run flow profile (minimizes turbulence)
- Clean and dry

**Slurries:**

- Consistent process composition & temperature
- Sufficient straight run flow profile (minimizes turbulence)

**Emulsion:**

- Consistent process composition & temperature
- Sufficient straight run flow profile (minimizes turbulence)

**Undesirable Process Conditions**

**Liquids:**

- Inconsistent process composition or temperature
- Insufficient straight run
- Turbulence
- Aerated fluids

**Air & Gas:**

- Inconsistent process composition or temperature
- Wet or saturated air/gas

**Slurries:**

- Inconsistent process composition or temperature
- Insufficient straight run
- Turbulence
- Aerated fluids

**Emulsion:**

- Inconsistent process composition & temperature
- Insufficient straight run
- Turbulence
- Aerated fluids

**Solids:**

- Dry granulated processes are NOT good candidates for thermal switches

**Application Principles - Flow, Level, Interface & Temperature**

- ✓ Consistent process composition
- ✓ Consistent process temperature
- ✓ Clean or dirty process
- ✓ Liquids
- ✓ Dry air & gas
- ✓ Slurries
- ✓ Emulsion
- ✗ Aerated fluids
- ✗ Large temperature swings
- ✗ Wet or saturated air/gas
- ✗ Solids
- ✗ Sediment covering sensing tip

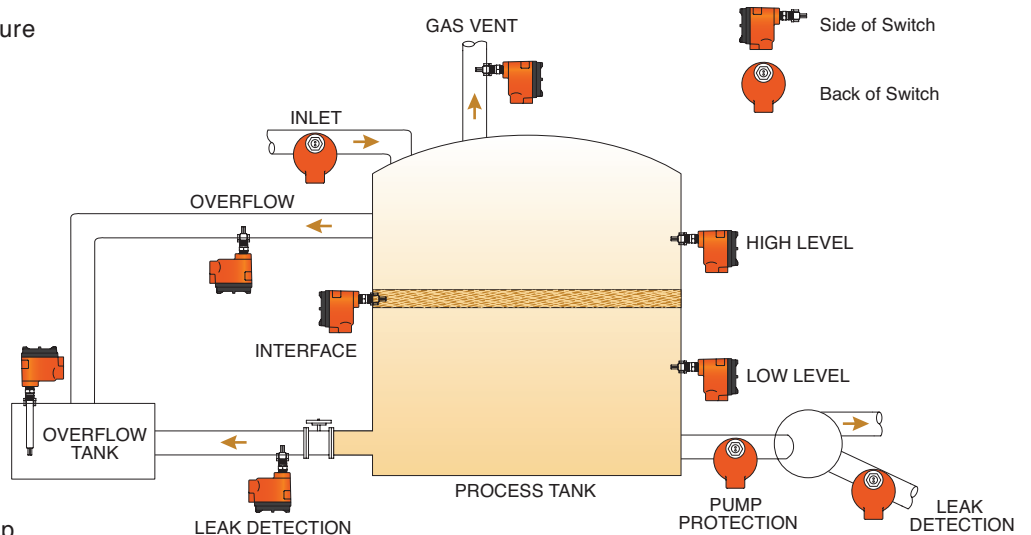

**Application Considerations - Level**

**Level**

**Ideal Process Conditions**

**Liquids:**

- Consistent process composition
- Non-turbulent

**Slurries:**

- Consistent process composition

**Emulsion:**

- Consistent process composition

**Undesirable Process Conditions**

**Liquids:**

- Inconsistent process composition
- Turbulence
- Large temperature swings

**Slurries:**

- Inconsistent process composition
- Turbulence
- Large temperature swings

**Emulsion:**

- Inconsistent process composition
- Turbulence
- Large temperature swings

**Solids:**

- Dry granulated processes are NOT good candidates for thermal switches

**Application Considerations - Interface**

**Interface**

**Ideal Process Conditions**

**Liquids:**

- Liquid to Liquid:
- Consistent process composition & temperature
- Non-turbulent applications
- Large differential in thermal conductivities

**Air or Gas to Liquid:**

- Consistent process composition & temperature
- Non-turbulent applications
- Dry gas

**Emulsion:**

- Consistent process composition & temperature
- Large differential in thermal conductivities

**Undesirable Process Conditions**

**Liquid to Liquid:**

- Inconsistent process composition or temperature
- High aeration
- High turbulence
- Small differential in thermal conductivities

**Air or Gas to Liquid:**

- Inconsistent process composition or temperature
- High turbulence

**Emulsion:**

- Inconsistent process composition or temperature
- High aeration
- High turbulence
- Small differential in thermal conductivities

**Solids:**

- Dry granulated processes are NOT good candidates for thermal switches

### III. GUIDELINES FOR PIPE MOUNTING

The CLASSIC 800 is a flow, point level, interface and temperature sensing device. The sensor tip must be inserted in the proper location and to the proper depth in order to accurately react to your process conditions. The following information, including Figures 5 through 9, should be considered as text book examples for proper installation.

**Notes:** Most pipe connections for instrumentation are a variation of a butt-weld-type such as the weldolet or thredolet shown in Figure 4. The length of this connection must be added to the pipe diameter when determining the insertion length for the sensor. The Kayden literature refers to this “insertion length” dimension as the “U” length, Figure 5.

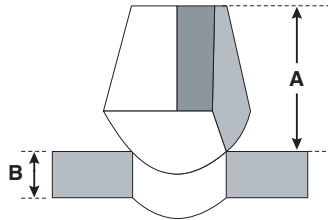

**Thredolet**  
Conforms to ASME B16.1

**Figure 4 - Thredolet**

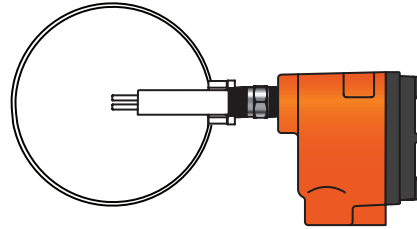

**Figure 5 - Insertion 'U' Length**

#### Horizontal Pipe - Side Mount (Ideal)

As shown in Figure 6a, ensure sensing tip is inserted to a point between 5% and 75% of the inside diameter of the pipe. Avoid locations where sediment may accumulate and isolate the sensing tip from the process.

#### Horizontal Pipe - Top Mount

Gas will always collect at the top of any pipe, ensure sensing tip is inserted to a point where it will be constantly and fully exposed to the desired process media.

#### Horizontal Pipe - Bottom Mount

Because sediment will always collect at the bottom of any pipe, ensure sensing tip is inserted to a point where it will be constantly and fully exposed to the desired process media. Avoid locations where sediment may accumulate and eventually isolate the sensing tip from the process.

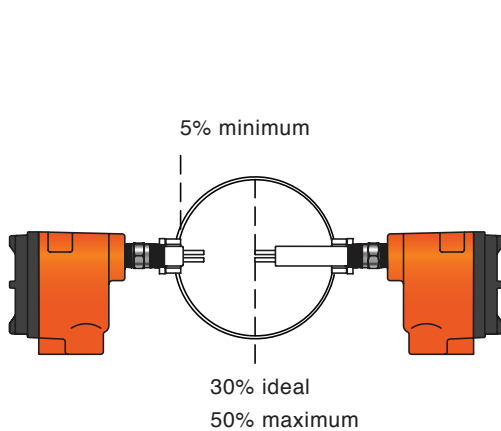

**Figure 6a - Horizontal Pipe, Side Mounting**

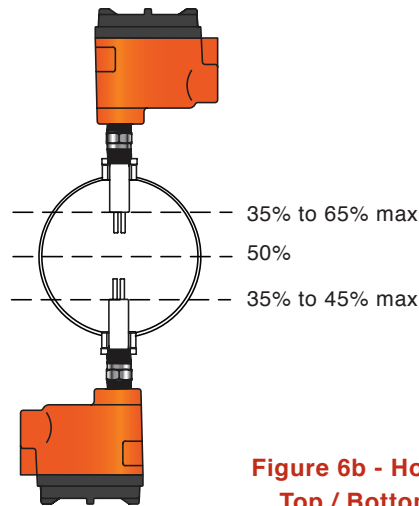

**Figure 6b - Horizontal Pipe, Top / Bottom Mounting**

For vertical pipe mounting, Kayden strongly recommends installing the switch/transmitter at a point of UPWARD process flow to ensure continued total immersion of the sensing tip.

If there is no other option except to install the flow switch/transmitter in a vertical pipe with downward flow, the following information must be considered:

- A “waterfall effect” may occur in vertical pipe with low flow rates. The process may become substantially aerated and will therefore cause the switch/transmitter to interpret the aeration as a lower flow rate (see Figure 8).
- The line should be full liquid/slurry at all times.
- The switch/transmitter must be far enough from an open outlet that air cavitation does not extend to the sensing tip and cause a false flow signal. A constriction at the outlet avoids this problem.

**Vertical Pipe - Side Mount (Acceptable)**

- Ensure sensing tip is fully inside the pipe wall as a minimum and to the center of the pipe as a maximum.
- When installing the switch in vertical piping, Kayden strongly recommends installing thermal switches at a point of UPWARD process flow to ensure continued total immersion of the sensing tip.

**Vertical Pipe - Side Mount - Downward Flow:**

- Is only recommended for higher flow rates where the LINE IS KEPT FULL OF LIQUID/SLURRY.
- For installation in a vertical gravity flow, the switch must be distant enough from an open outlet that air cavitation does not affect the sensing tip and cause a false flow signal. A constriction at the outlet avoids this problem.
- A waterfall effect will occur in vertical pipe with low flow rates. Also, the process is likely to become substantially aerated. The switch will interpret the aeration as a substantially lower flow rate and possibly cause a false low flow alarm.

**Vertical Pipe - Side Mount - Top & Bottom Mount (Less Desirable)**

Positioning the sensor on a corner or elbow is not recommended as the process will be turbulent. The switch may interpret the turbulence as a constantly changing flow rate and fail to alarm as required.

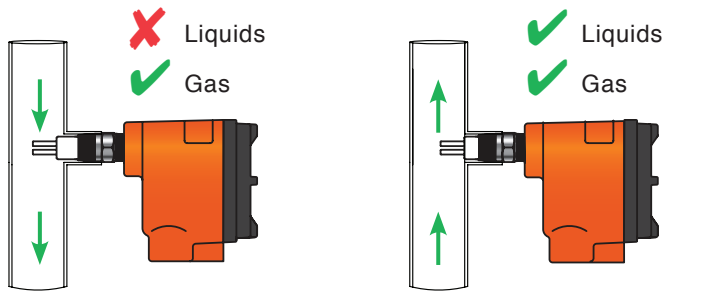

**Figure 8 - Vertical Pipe, Flow Up & Down**

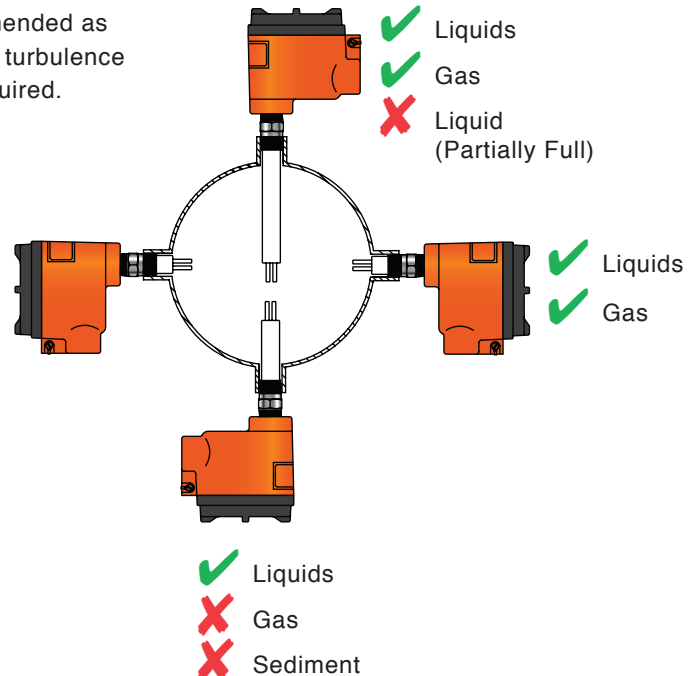

**Figure 7 - Horizontal Pipe, Sensor Positioning**

## IV. INSTALLING THE SENSOR

Having followed the installation guidelines in Section 2, “Installation Guidelines”, Subheadings I through III, you may now proceed with installation.

**CAUTION**

1. Use proper eye protection and any other safety equipment as required by your installation site.
2. Check electrical power to ensure that all power has been disconnected and ‘locked out’.
3. Ensure the process tank and/or line pressures are ‘zero’.
4. Ensure that steam, hot water, acids or any other potentially hazardous media will not be released.
5. Follow all safety precautions as specified for your installation site and / or local codes.

### 1. Process Connections

- Threads: Coat with a thin layer of thread tape or sealant/lubricant. Do not overtighten threads when installing.
- Flanges: To ensure a correct seal on mating flanges, mount and tighten flanges according to ANSI standards.

### 2. Sensor Orientation

- To optimize the sensor’s performance ensure the sensor is positioned as outlined below. As shown in Figure 9 below, ensure the arrows etched on the sensor flats are oriented parallel to the process flow.

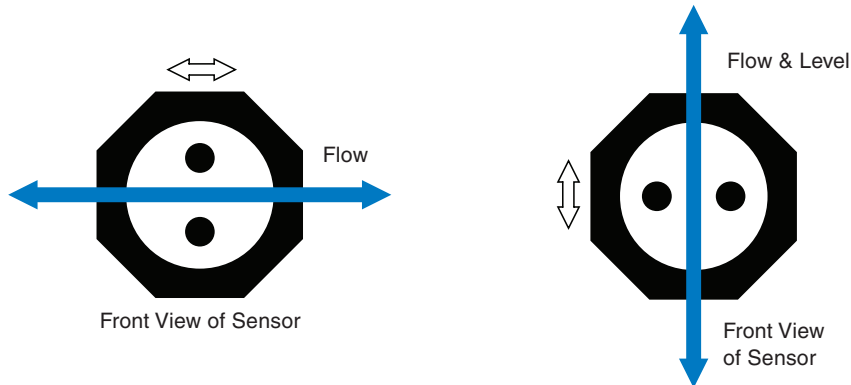

**Figure 9 - Sensor Orientation for Horizontal Flow & Level**

- Notes:**
1. Liquids & Slurries: When mounted in a tee or section of pipe larger than the normal process pipe, position sensor at a sufficient insertion point so as to avoid contact with any air or gas bubbles that occur in the larger section of pipe.
  2. Avoid locations where sediment may accumulate and eventually isolate the sensing tip from the process. Sediment covering the sensor tip may prevent the switch/transmitter from being able to sense any changes in the process as the sediment will insulate the sensing tip.



## V. ELECTRICAL

### 1. General

- Ensure all electrical installation is in accordance with all applicable local and national electrical code requirements. The CLASSIC 800 series standard configuration includes an explosion-proof enclosure. The CLASSIC 800 Series is FM approved, Canadian Standards Association (CSA) and Underwriters Laboratory (UL) standards and must be installed in accordance with these applicable codes and standards.



- **Power Supply:** For applications using a DC power supply, ensure the power has less than 2% ripple.
- **Switch/Transmitter Enclosure:** The switch/transmitter enclosure must be grounded in accordance with local and national electrical codes. The most effective grounding method is a direct internal connection to earth ground with minimal impedance. The (green) Internal Ground Connection screw is located inside the electrical enclosure and is identified by the universal ground symbol.

### CAUTION

1. Mount the enclosure so that moisture/liquids will not enter the switch/transmitter enclosure. If conduit connections are not sealed, moisture accumulation can damage the switch/transmitter.
2. Grounding the switch/transmitter enclosure via threaded conduit connection may not provide sufficient ground continuity.
3. Do not run the transient protection ground wire in the same conduit as the signal wiring as the ground wire may carry excessive current if a lightning strike occurs.

### 2. Wiring Connections to the Switch/Transmitter

- To make the electrical connections to the CLASSIC 800, it is necessary to remove the Electronics Module as follows:
  - A. Remove the Cover:**
    - Turn the external stainless steel locking screw clockwise with a 5/32" (#10) Allen Key and turn the cover counter clockwise until it can be lifted off the enclosure.
  - B. Remove the Electronics Module:**
    - To remove the Electronics Module, pull upward with an equal force on both stainless steel handles. Care should be taken to avoid damaging the sensor cable attached to the Electronics Module. Practice ESD (electrostatic discharge) procedures when handling the Electronics Module.
    - Electrostatic discharge may damage the electronics! Never place the Electronics Module on a surface or pass it to another person in a way that would allow an electrostatic discharge to pass through it.
  - C. Removing the Sensor Connector from the Electronics Module:**
    - Refer to Figure 10.
    - The Electronics Module must be removed from the enclosure before any wiring can be connected to the Mounting Base Plate. Disconnect the sensor connector from the Electronics Module by disengaging the locking tab and pulling (with fingers) on the corners of the small black connector. Do not pull directly on the wires. The use of pliers may damage the connector.



**Figure 10 - Disconnecting Sensor Connector from the Electronics Module**

• **Input Power Connections:**

The CLASSIC 800 will accept 12-24 VDC or 115-230 VAC input power via the universal power supply by wiring the Electronics Module according to input power available.

- For AC power, connect the HOT line to VAC-H, the NEUTRAL to VAC-N and the GROUND wire to the green grounding screw in the enclosure, also indicated by the ground symbol.
- For DC Power, connect the positive voltage to +VDC and the common or negative to COM. (see Figure 12 - Wiring Connection Diagram)

• **Wiring the Relay Contact(s):**

- The CLASSIC 800 features two (2) sealed independent relays, which may be wired for Normally Closed (NC) or Normally Open (NO) operation. Relay 1/Relay 2 are connected as shown in Figure 12.

• **Replacing the Electronics Module in the Enclosure:**

Repeat steps 2B and 2C in reverse order. The cable from the sensor to the Electronics Module should be gently positioned between the outside of the Mounting Base Plate with green & black connectors and the inside of the enclosure. If the excess length of the cable interferes with the mounting of the Electronics Module then gently rotate the Electronics Module one full turn to put a twist in the sensor cable.

- There is no surplus room in the enclosure for excessively long wires.
- Use a quality data communications cable for all non-power connections (RS-485). Ensure that the shield is sufficient to allow the cable to coexist with the power connections. Consult your local electrical code for requirements.
- All wires must be kept free and clear of the green & black mounting connectors on the Mounting Base Plate to prevent interference with the mounting of the Electronics Module.
- Treat the Electronics Module and sensor cable with care. While the CLASSIC 800 is a rugged unit, these assemblies can be damaged if mishandled.

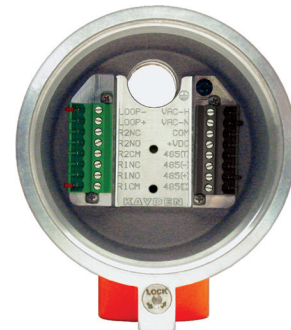

**Figure 11 - CLASSIC 800 Mounting Base Plate / Wiring Terminal**

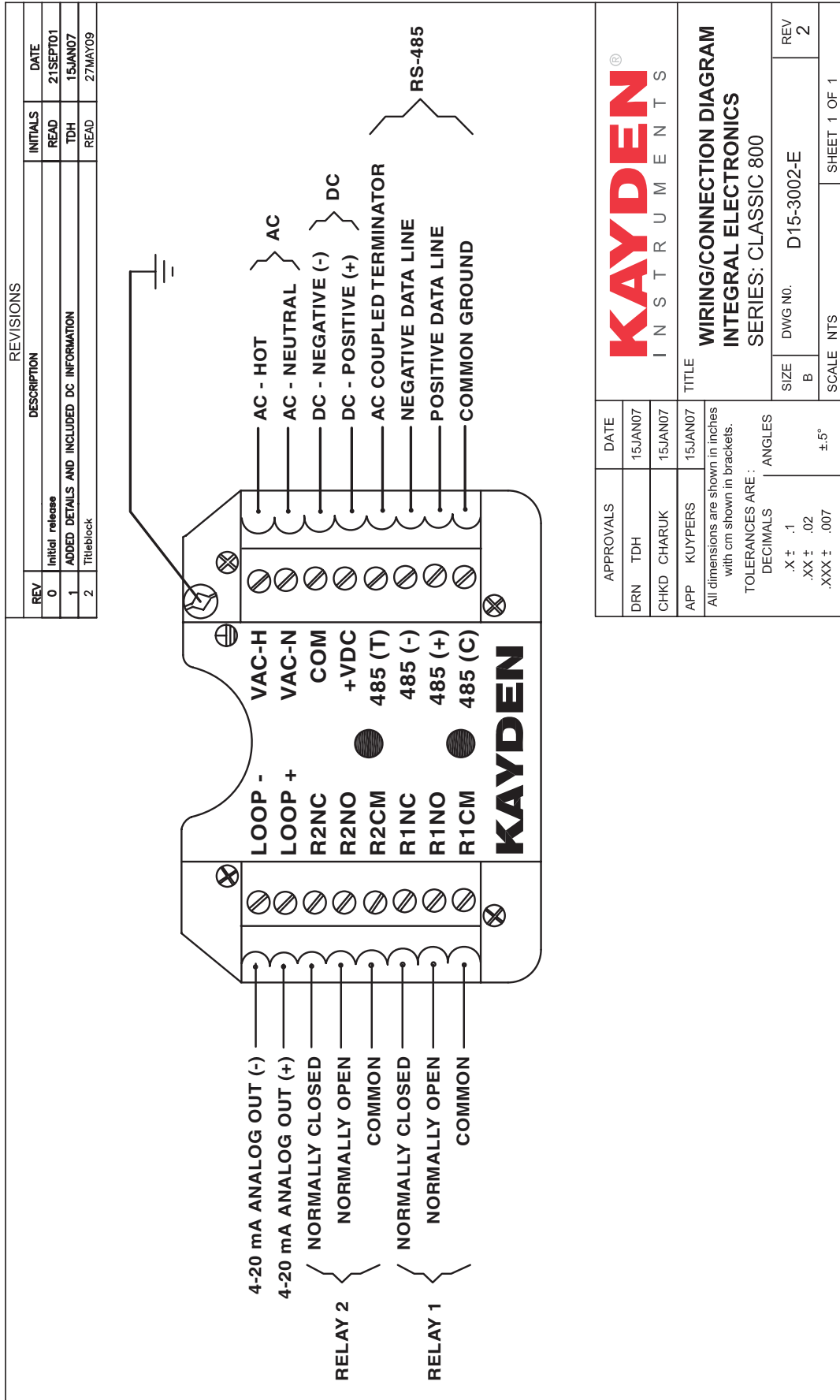

Figure 12 - CLASSIC 800 Wiring Connection Diagram

## VI. TESTING THE INSTALLATION

### 1. Self-test Diagnostics

- The CLASSIC 800 continuously executes a self-test on its internal components and firmware. All diagnostics are controlled by the microprocessor and are independent of the operation of the switch/transmitter and the process conditions.
- At initial power-on the CLASSIC 800 performs a complete self-test of all hardware and firmware. During this test all LEDs on the Thermal Signal display will flash for approximately 2 seconds.
- If a Fault is discovered during the self-test a Fault Code will be displayed and the relay will de-energize. (Fault Codes are explained in **Section 7 “Troubleshooting”**).

### 2. Power

- Turn on the power to the switch/transmitter and **allow the sensor to heat up and stabilize (approximately 90 seconds)**.
- At the conclusion of the self-test, if there is no fault condition present, the Run Mode LED will begin flashing and a single LED (in the Thermal Signal Bar Graph) will appear on the display. As the heater element warms up, the switch/transmitter will respond to the process conditions and this LED indicator will move to the left.
- Relay 1 and/or Relay 2 LEDs may illuminate depending upon the Thermal Signal, relay set point(s) and the programmed Relay condition (set to energize ABOVE or BELOW set point).

### 3. Manual Test

- Immerse the sensing tip in the actual process media by filling the pipe or vessel to the point at which the switch/transmitter will actuate or alternatively, into a container of process media.
- When the sensor is alternated between wet and dry conditions (in and out of the media), the illuminated Thermal Signal LEDs should move and the relay set point LED(s) should change state (ON/OFF). The degree and speed of the movement of the Thermal Signal LED depends completely on how well the current setup of the CLASSIC 800 corresponds to the process conditions of the test.\*  
**Note:** \*Because a complete setup may not have yet been performed allow at least 20 - 30 seconds for the sensor and relay to react when alternating between wet and dry conditions (in and out of the media).
- A complete explanation of setup procedures follows in **Section 3 “Setup & Operation”** and in the **Quick Setup Guide** for the CLASSIC 800.

3

Setup & Operation



Figure 1 - CLASSIC 800 Display Panel

Display Panel Indicators:

- Relay 1** On steady when Relay 1 is energized
- Relay 2** On steady when Relay 2 is energized
- Fault** Indicates a self-test error or fault condition
- Set Point 1** On steady when viewing Set Point 1
- Set Point 2** On steady when viewing Set Point 2
- Run Mode** Flashing when switch is operating
- Bypass** Flashing when the Start-up Bypass Timer is active
- Thermal Signal** Displays Thermal Signal

The Thermal Signal increases as:

- Flow** The flow rate increases
- Level** The sensor is submerged
- Interface** The sensor is submerged by the second liquid of greater thermal conductivity

Display Panel Button Functions - RUN Mode and SET Mode.

RUN MODE - Run Mode LED is 'Flashing'	
RUN	Press and hold to view the <b>Software Revision</b> and <b>Node Address</b>
SET	Press and release to enter <b>Set Mode</b> (see table below)
Left Arrow	Press and hold to view the LED-0 and LED-100 Pointers on Baseline graph
Right Arrow	Press and hold to view Thermal Signal data on Baseline Graph
1	Press and hold to view <b>Set Point 1</b> on Scaled Bar Graph View
2	Press and hold to view <b>Set Point 2</b> on Scaled Bar Graph View

SET MODE - Run Mode LED is 'Off'	
RUN	Press and release to exit <b>Set Mode</b> and return to <b>Run Mode</b>
SET	Press and release to proceed to next step of <b>Set Mode</b>
Left Arrow	Adjust selection as per <b>Set Mode</b> function
Right Arrow	Adjust selection as per <b>Set Mode</b> function
1	No function in <b>Set Mode</b>
2	No function in <b>Set Mode</b>

Figure 14 - Control Functions RUN/SET Mode

## I. GENERAL INFORMATION

### 1. Warm-up

At initial start-up or restart allow approximately 90 seconds for the heater element to warm-up and the switch/transmitter to stabilize before making any adjustments.

### 2. Diagnostics

As described in greater detail in **Section 7 “Troubleshooting”** an automatic diagnostic program runs continuously when power is connected. To prevent the possibility of intermittent failures the CLASSIC 800 will display a Fault condition in the event of improper electrical connection, loss of power and / or extensive physical damage.

### 3. Universal Power

The CLASSIC 800 will accept either 12-24 VDC or 115-230 VAC but must be wired accordingly.

The CLASSIC 800 may not be loop powered. At a minimum the unit requires 4 wires: Hot and Neutral for AC/DC, R1COM and R1NO (see Figure 12 - CLASSIC 800 Wiring Connection Diagram).

Power consumption for the CLASSIC 800 is rated at a maximum of 6 VA (watts). The maximum rating is based on the assumption that both relays are energized, the heater is at maximum power and several LEDs are illuminated. An application involving the relay energized and the heater at 80% power consumes typically 300 mA or 4 VA.

### 4. Electronics

The CLASSIC 800 Electronics Module is universal and may be installed for testing or operation in all

CLASSIC 800 series switches/transmitters regardless of sensor configuration. Therefore, the Electronics Module may be considered a universal spare part and the most essential troubleshooting tool for all applications.

## II. CONTROL SETTINGS and SETUP PROCEDURES

### Quick Setup Guide

The CLASSIC 800 Quick Setup Guide, **Section 4 “Quick Setup Guide”**, contains the required information to facilitate setup and adjustments. The setup procedures contained in **Section 3** of this manual are listed in the same order as the programming matrix in the Quick Setup Guide which is included in this manual as Section 4. Additional copies of the Quick Setup Guide may be obtained from [kayden.com](http://kayden.com).

### 1. View or Adjust Relay 1 & 2 Energized Mode

Both relays on the CLASSIC 800 have Normally Open and Normally Closed contacts. The terms ‘Open’ and ‘Closed’ refer to the de-energized state of the relays. Normally Open or Normally Closed operation for **Relay 1/ Relay 2** is determined by wiring the contacts accordingly (see Figures 11 & 12).

**Note:** Low flow means less Thermal Signal as represented by the CLASSIC 800’s Thermal Signal Bar Graph. Some configurations may require one or both relays to be energized on high flow, i.e. higher than the set point.

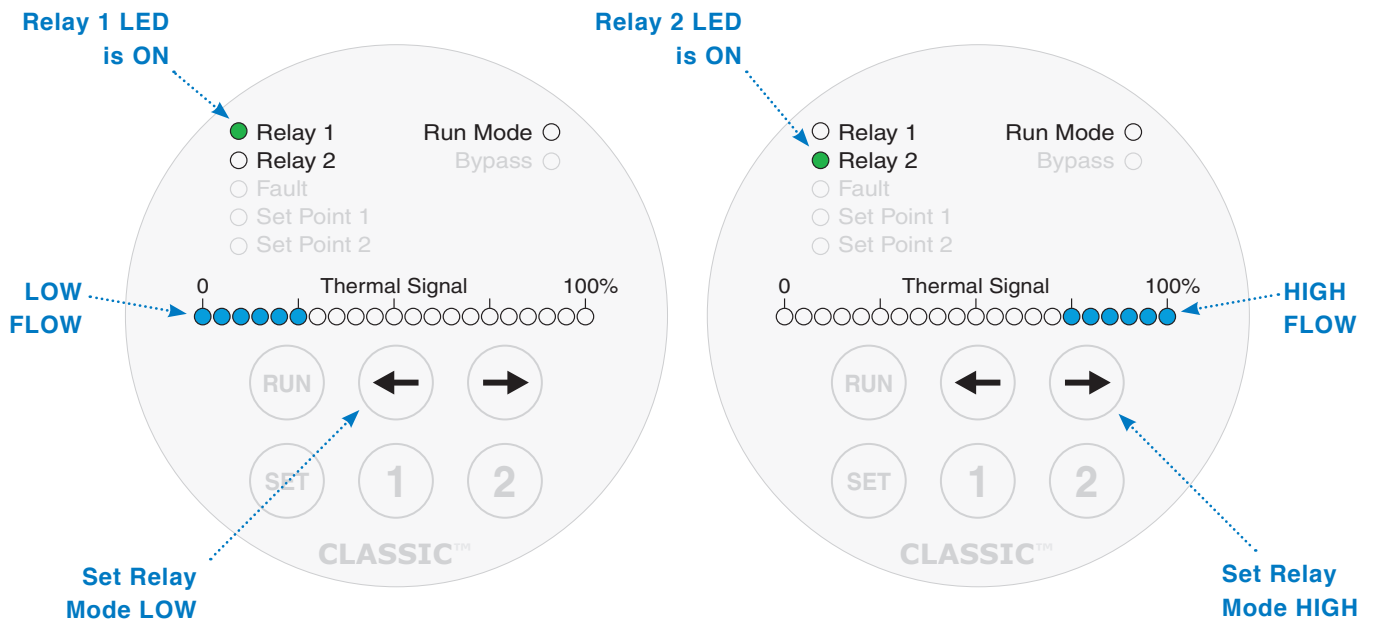

- **RUN** advances to Run Mode
- **SET** advances to next Setup step
- **Run Mode** LED is Off in Setup Mode

Figure 15 - Relay Energized Mode

#### To View or Adjust the Relay 1 & 2 Energized Modes:

1. Press **SET** until the **Relay 1** or **Relay 2** LED is on solid and the **Run Mode** LED is off.
2. The **Thermal Signal Bar Graph** shows the Relay Mode. For Low Flow the first six (**0-25% LED's**) are on solid; for High Flow the last six (**75-100% LED's**) are on solid.
3. To adjust the Mode, press and release the **Left** or **Right** Arrow keys.
4. When satisfied with your configuration, press and release **SET** to continue to the next programmable variable OR press and release **RUN** to return to **Run Mode**.

### Failsafe Relay Configurations

The term “Fail-safe” refers to a method of wiring and programming control instrumentation commonly used in hazardous locations/applications.

- In a “Fail-safe” application the CLASSIC 800 switch/transmitter is wired and programmed so that the output relay is energized in normal process operating condition.
- Thus, in the event of a power failure, cable break, self-test failure, or other loss of electrical power, the contact is “opened”, the relay is de-energized and an alarm will result.

A common “Fail-safe” setup for **NO FLOW CONDITION, PUMP PROTECTION:**

- Connect the relay contact wires to Normally Open (R1NO, R1CM)
- Program the relay(s) to energize above set point.
- Depending on application and setup of the switch/transmitter, the relay contact(s) will OPEN (de-energize) when:
  - a. The Thermal Signal decreases due to a decrease or loss of flow/level.
  - b. Power is lost to the switch/transmitter as described above.



## 2. View or Adjust the 4-20 mA Fault Mode Configuration

The 4-20 mA output is used to monitor the analog data from the sensor, such as a self-test fault. The 4-20 mA output can be programmed for a value of 3.0 mA or 21 mA.

**Note:** For more general information on fault conditions, see **Section 7 “Troubleshooting”**.

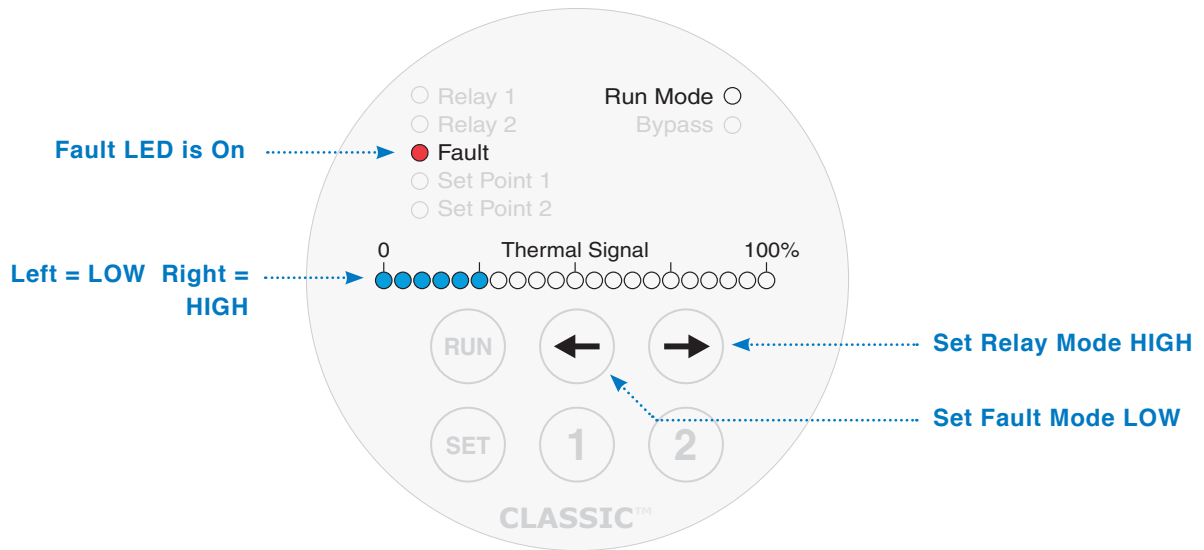

- **RUN** advances to Run Mode
- **SET** advances to next Setup step
- **Run Mode** LED is Off in Setup Mode

**Figure 16 - 4-20 mA Fault Mode Configuration**

### To View or Adjust the Fault Current:

1. Press and release **SET** until the **Fault LED** is on solid; the **Run Mode** LED will be off.
2. The **Thermal Signal Bar** Graph shows the 4-20 Fault Mode.  
For **3.0 mA** the **0-25% LED's** are on solid;  
for **21 mA** the **75-100% LED's** are on solid.
3. To adjust the Mode, press and release the **Left** or **Right Arrow** keys.
4. When satisfied with your configuration, press and release **SET** to continue to the next programmable variable OR press and release **RUN** to return to **Run Mode**.

### 3. View or Adjust Set Points 1 & 2

- Notes:**
1. Viewing either **Set Point 1** or **2** from the Display Panel does not require entering the Manual Setup Mode. While still in **RUN Mode**, press and hold **1** or **2** to view the programmed **Set Point**.
  2. In this context “Set Point” refers to the point(s) within the user defined range at which **Relay 1** and **Relay 2** energize/de-energize.
  3. **Set Point 1** always corresponds to **Relay 1** and **Set Point 2** always corresponds to **Relay 2**.

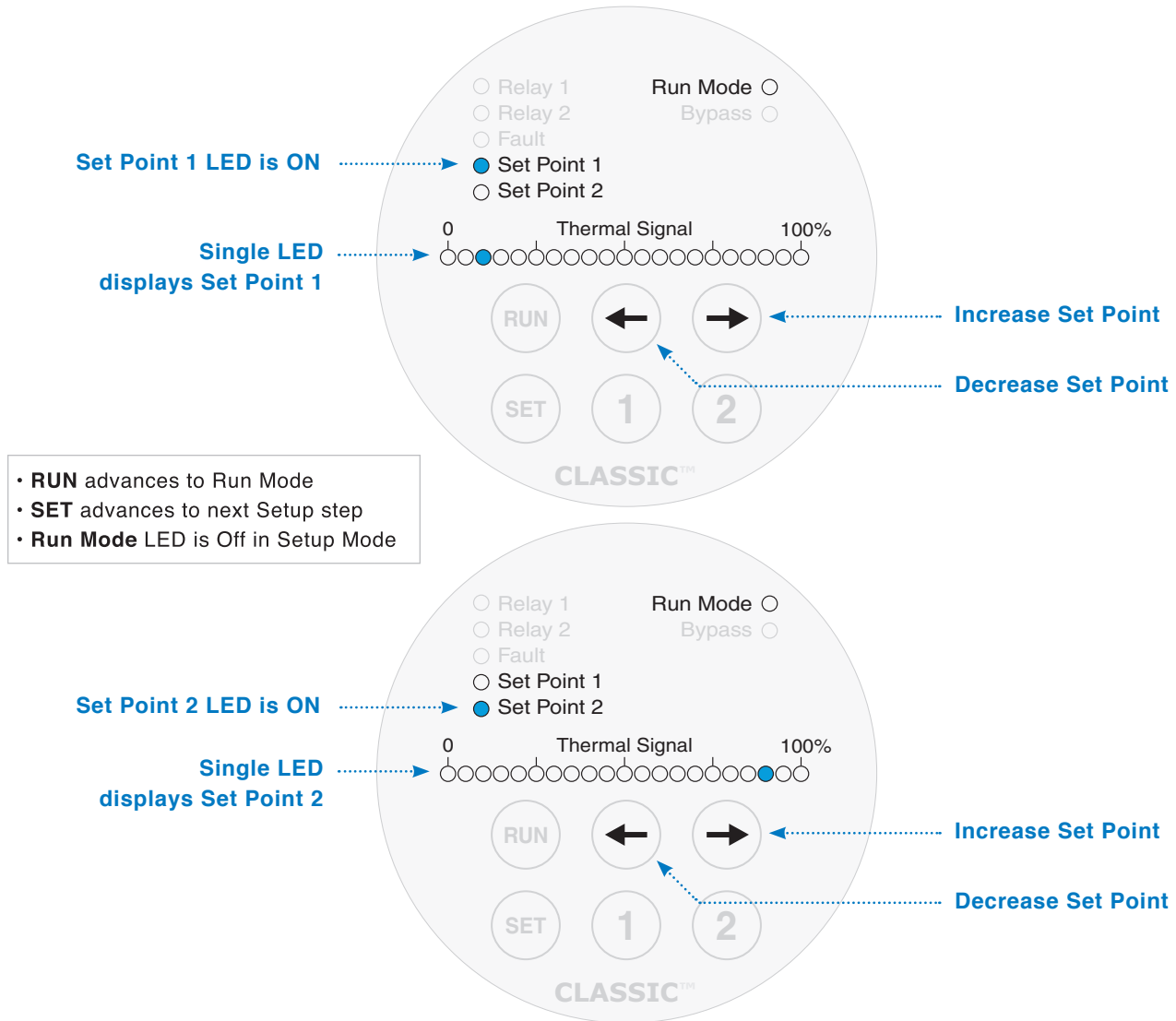

Figure 17 - Set Point 1 & 2 Configuration

#### To View or Adjust the Set Points

1. Press and release **SET** until the **Set Point 1** or **Set Point 2** LED is on solid and the **Run Mode** LED is off.
2. One LED on the **Thermal Signal Bar Graph** will illuminate, corresponding to the present setting of the selected set point.
3. To adjust the selected **Set Point**, press and release the **Left** or **Right Arrow** keys.
4. When satisfied with your configuration, press and release **SET** to continue to the next programmable variable OR press and release **RUN** to return to **Run Mode**.

#### 4. View or Adjust the Start-up Bypass Timer

The Start-up Bypass Timer provides a means to energize both relays when the switch/transmitter is initially powered on. This feature provides a means to automatically restart a pump that has been turned off by the switch/transmitter without the need for additional hardware.

- Notes:**
1. The Start-up Bypass Timer is commonly used to automatically re-start a pump after the specified (programmed) time delay.
  2. During the Bypass Delay, both relays are energized regardless of their Mode or the value of the **Thermal Signal**.
  3. When the Start-up Bypass Timer is in use, neither Setup Mode nor the Thermal Signal Bar Graph are available until the programmed delay time expires.

The **Thermal Signal Bar Graph** displays the delay (each LED right of the zero LED in Bypass Mode equals 5 seconds; therefore the maximum time in Bypass is 100 seconds). Instead of measuring from 0 to 100 percent the **Thermal Signal Bar Graph** shows the delay from 0 to 100 seconds.

If the **Start-up Bypass Timer** is set to zero then no Bypass Delay will occur.  
(The Factory Default setting is **zero seconds**.)

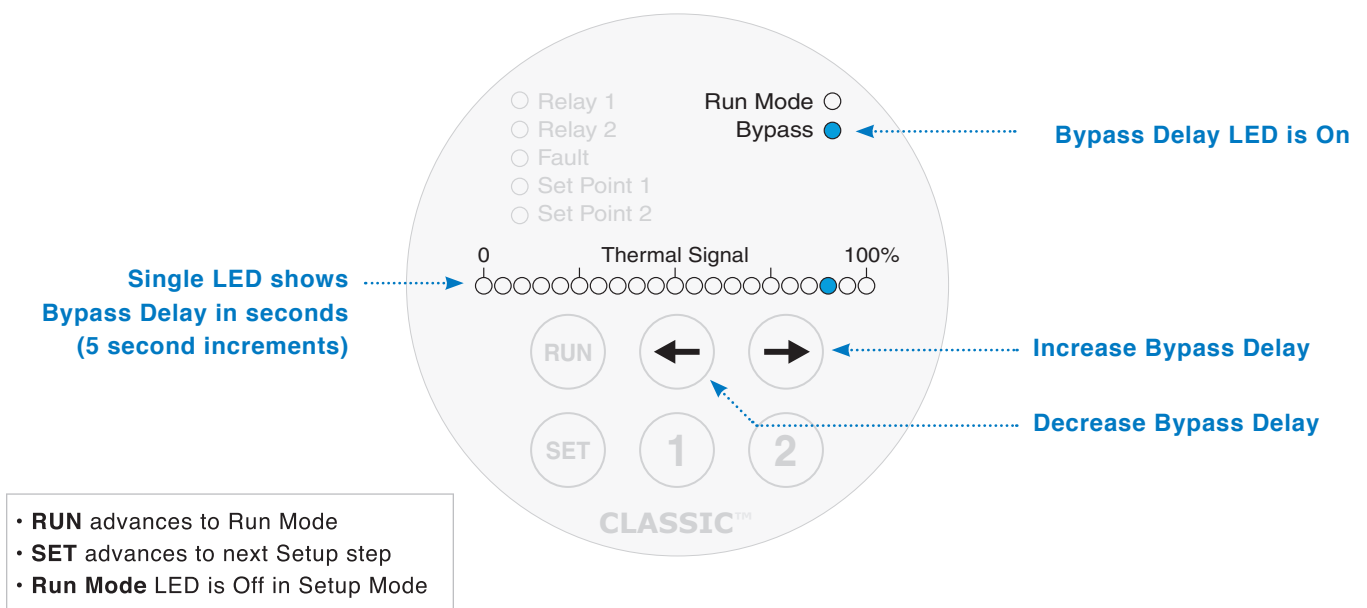

Figure 18 - Start-up Bypass Timer

#### To View or Adjust the Fault Current:

1. Press and release **SET** until the **Bypass** LED is on solid and the **Run Mode** LED is off.
2. One LED on the **Thermal Signal Bar Graph** will illuminate corresponding to the present setting of the **Start-up Bypass Timer**.
3. To adjust the **Start-up Bypass Timer**, press and release the **Left** or **Right** Arrow keys.
4. When satisfied with your configuration, press and release **SET** to continue to the next programmable variable OR press and release **RUN** to return to **Run Mode**.

### 5. View or Adjust the Heater Power

- The correct heater setting is determined primarily by the process media and secondarily by the velocity of the process. The heater setting is a key factor in determining the sensitivity and reaction time of the switch/transmitter.
- The Factory Default setting of 75% is optimal (70 - 80% depending on velocity) for Hydrocarbon-based liquids and suitable for many applications. The CLASSIC 800 allows the Heater Power to be set between 0% and 100% in 5% steps.

• GUIDELINES FOR SETTING HEATER POWER:

- **30 - 60% heater power (7-13 LEDs)** - Air or Gas (Flow) (depending on velocity)
- **60 - 75% heater power (13-16 LEDs)** - Oil or Hydrocarbon based liquids (Flow, Level & Interface)
- **80 - 100% heater power (17-21 LEDs)** - Water or non-viscous liquids (Flow, Level & Interface)

The faster the flow rate (velocity) the more heat is required. In level applications the amount of heat, in part, determines the reaction time.

- The CLASSIC 800’s sensor heater produces 2 watts at full power.
  - The main processor continuously and automatically monitors the heater element. This is the “Smart Heater” function. When the Thermal Signal decreases dramatically or goes to zero, the main processor will automatically reduce the output of the heater from the user setting to a lower power rating in order to prevent the creation of a “Thermal Offset”. This function will be automatically repeated until such time as the Thermal Signal increases.

**Note:** This function may be clearly observed in the graph function of the RCM software.

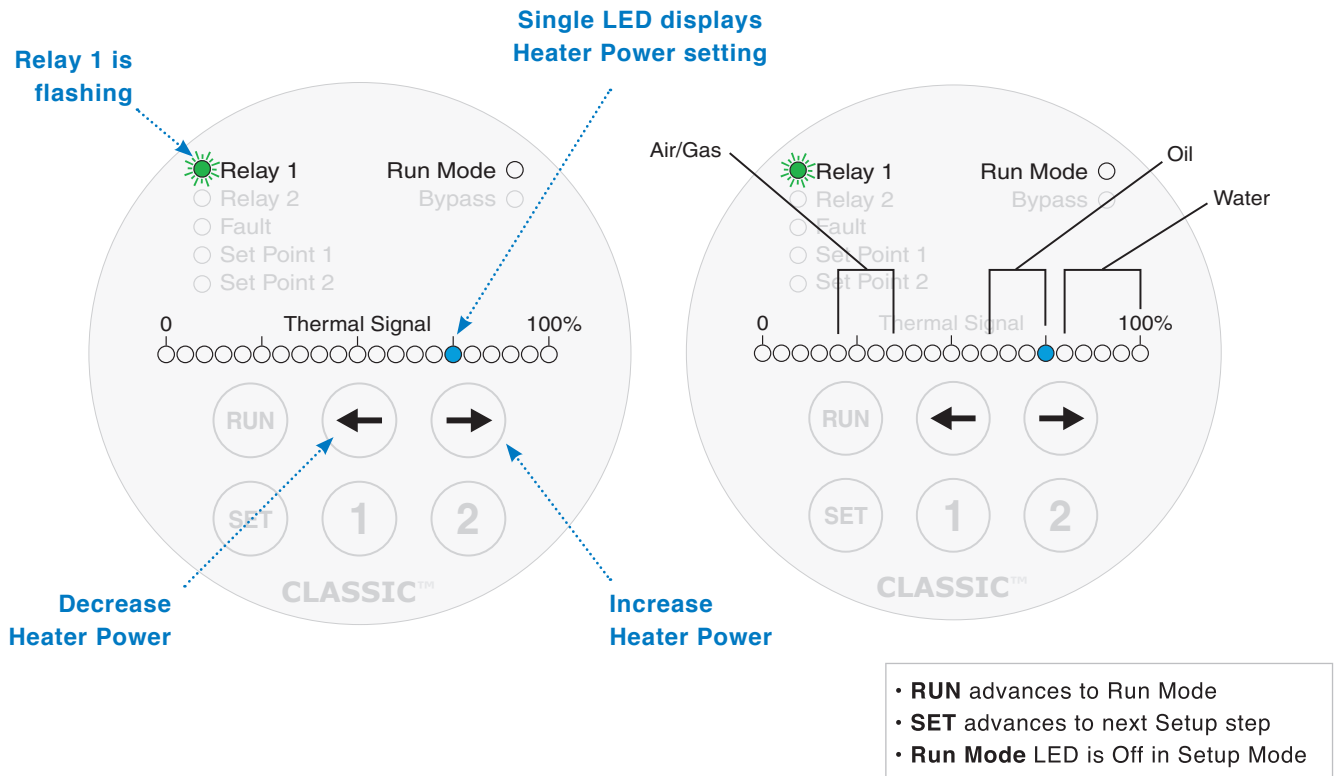

Figure 19 - Setting the Heater Power

## 6. View or Adjust the Node Address & View the Software Revision

The Software Revision and Node Address are displayed on the **Thermal Signal Bar Graph** as two binary bytes. The Software Revision is not adjustable but can be useful should telephone support be required.

**The Factory Default for the Node Address is 1 (one).**

Adjusting the Node Address is only required if setting up a multi-point RS-485 network or adding the CLASSIC 800 to an existing RS-485 network.

The Software Revision and Node Address can also be viewed while in **Run Mode** by pressing and holding the **RUN** key.

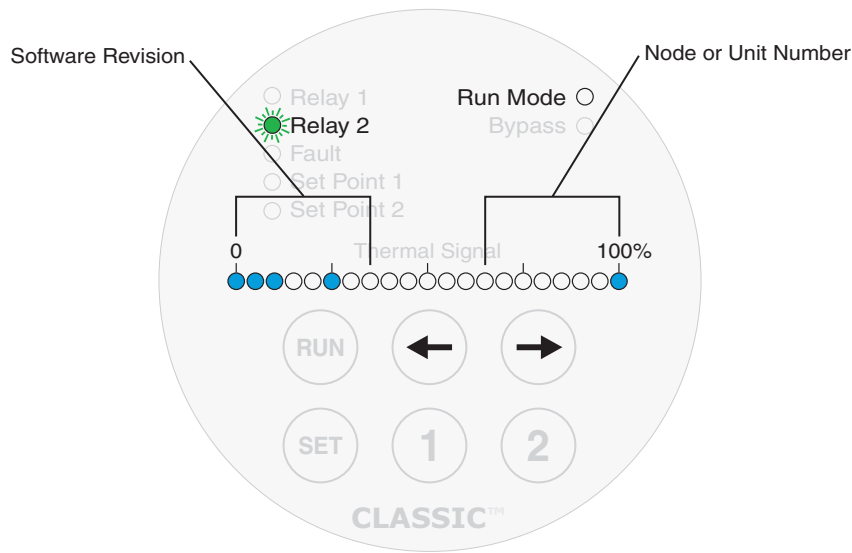

**Figure 20 - Software Revision & Node (Unit) Number**

### To View or Adjust the Node (Unit) Address:

1. Press and release **SET** until the **Relay 2** LED is **flashing** AND the **Run Mode** LED is off.
2. The **Thermal Signal Bar Graph** now displays the value of the Software Revision and the setting of the Node Address.
3. The Node Address is displayed in binary using the eight LED's on the righthand side of the Bar Graph. Refer to **Section 6 "Binary Table"**, for a listing of Node Address to LED patterns.
4. To adjust the Node Address, press and release the **Left** and **Right** Arrow keys.
5. When satisfied with your configuration, press and release **SET** to continue to the next programmable variable or press and release **RUN** to return to **Run Mode**.

### 7. View or Adjust the 4-20 mA Output Configuration (Forward or Reverse Polarity)

The 4-20 mA output is used to monitor the analog data from the sensor. The current output is an analog signal representing the Scaled Thermal Signal Bar Graph View.

Operator may select:

- 0% as 4 mA ascending to 20 mA
- 100% as 4 mA descending to 20 mA

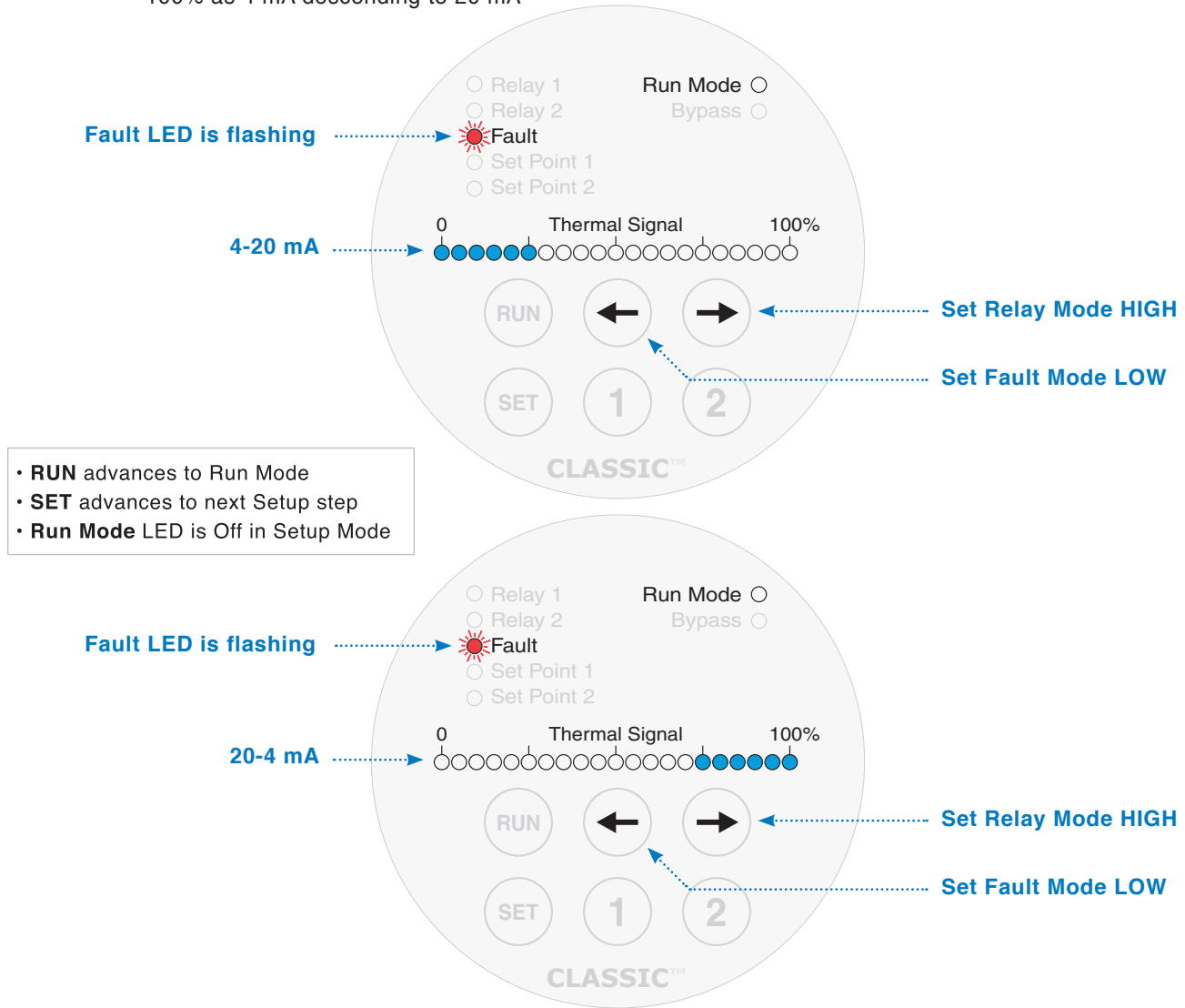

Figure 21 - 4-20 mA & 20-4 mA Output Mode

#### To View or Adjust the 4-20 mA Output Current Mode:

1. Press and release **SET** until the **Fault** LED is **flashing** AND the **Run Mode** LED is off.
2. The **Thermal Signal Bar Graph** shows the 4-20 Output Mode.
  - For 0% equal to 4 mA the 0-25% LED's are on solid.
  - For 100% equal to 4 mA the 75-100% LED's are on solid.
3. To adjust the Mode, press and release the **Left** or **Right Arrow** keys.
4. When satisfied with your configuration, press and release **SET** to continue to the next programmable variable OR press and release **RUN** to return to **Run Mode**.

### 8. View or Adjust the 0% & 100% Thermal Signal Scaled Bar Graph View

There are two views of the Signal Data available for display on the **Thermal Signal Bar Graph**.

1. The **Baseline Bar Graph View** shows the maximum possible span/complete thermal range that the CLASSIC 800 is capable of measuring.

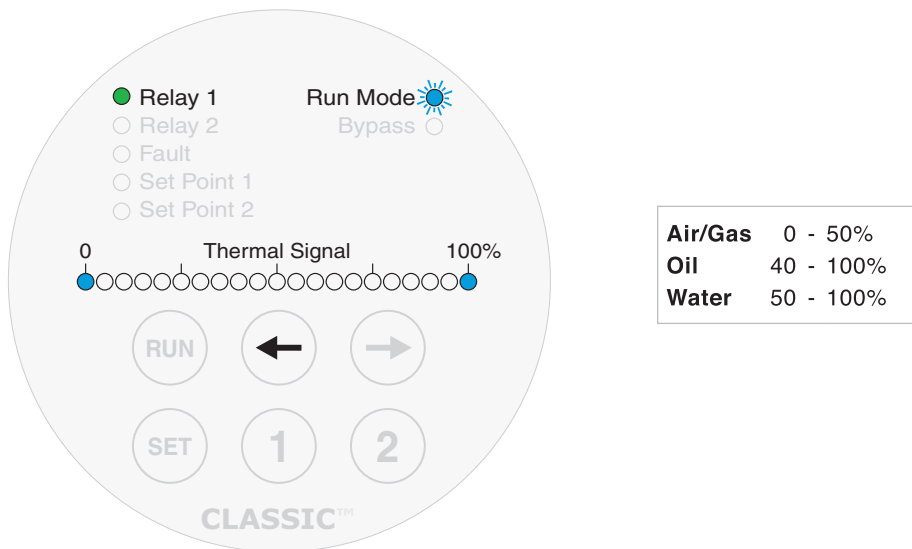

2. The **Scaled Bar Graph View** focuses only on the portion of the total thermal range required for each application (oil, water, gases). Once the 0% Thermal Signal and 100% Thermal Signal settings are defined, this range (**Scaled Bar Graph View**) will be displayed as 0% to 100% on the Thermal Signal Bar Graph at all times. The **Scaled Bar Graph View** can only be displayed by pressing and holding the **Left Arrow** while in **Run Mode**. When the zero (0%) and 100% LEDs illuminated, the switch is set for the widest range possible.

To illustrate this principle refer to Figure 22.

The LED-0 pointer is shown set to 50% of Baseline and the LED-100 pointer is shown set to 75% of Baseline. The result is that the Scaled View appears to zoom in on the area of the Baseline data that is framed by the LED-0 and LED-100 Pointers.

The data, indicated by the single illuminated LED, is at 55% of Baseline but on the Scaled View it is shown as 20%. This is because the data is at only 20% of the values framed by LED-0 and LED-100.

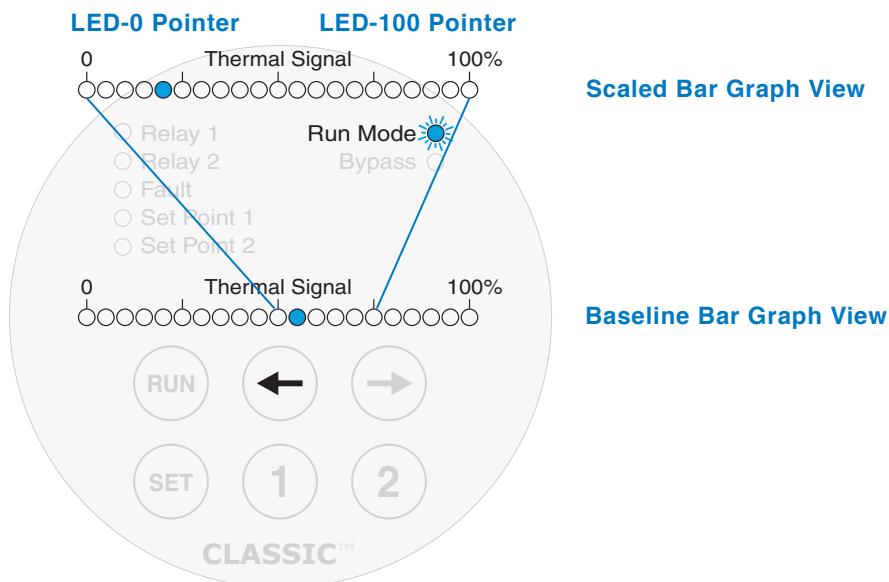

Figure 22 - Scaled Bar Graph View vs. Baseline Bar Graph View

9. View or Adjust the 0% & 100% Thermal Signal LEDs:

1. Press and release **SET** until the **Set Point 1** (LED-0) or **Set Point 2** (LED-100) status LED is **flashing** and the **Run Mode** LED is off.
2. The **Thermal Signal Bar Graph** now shows the setting of the LED Pointer.
3. To adjust the LED Pointer, press and release the **Left** or **Right Arrow** keys.
4. When satisfied with your configuration, press and release **SET** to continue to the next Programmable Variable OR press and release **RUN** to return to **Run Mode**.

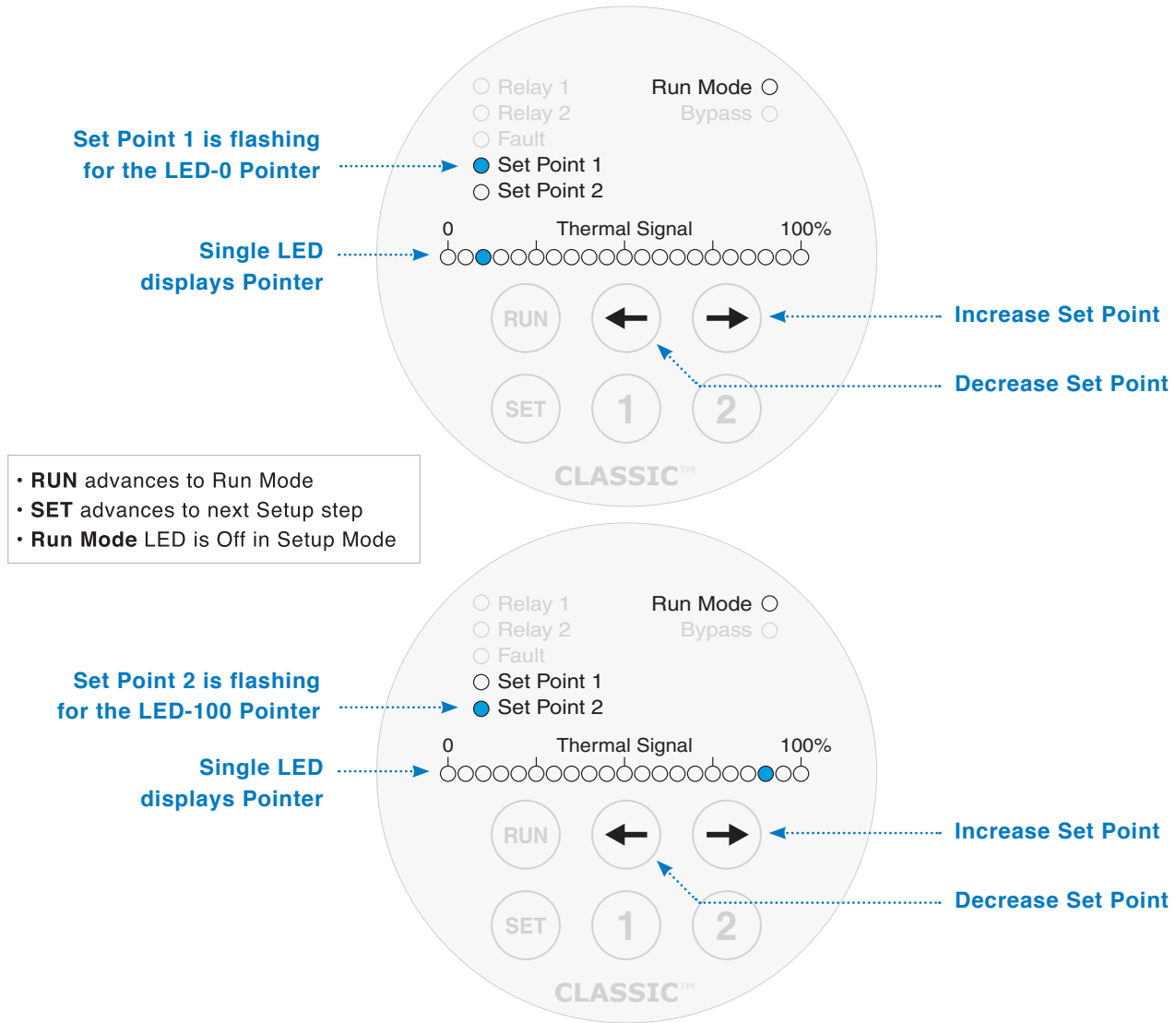

Figure 23 - Setting the 0% & 100% Thermal Signal



## Kayden RCM Software

Kayden designed powerful software specifically for remote configuring and monitoring of Kayden thermal flow, level, interface and temperature switches/transmitters from a PC. Remote connectivity lets you operate and/or configure your CLASSIC 800 from a central location. The **RCM Software** provides the ability to view or adjust: Set Points, Relay Modes, Temperature Mode, Start-up Bypass Timer, Heater Setting and Lock or Unlock the Display Panel.

The **RCM Software** includes a Thermal Graph screen which provides a graphical display of the process condition. The Thermal Graph displays the Thermal Signal and the Relay Set Point in either a line graph or chart recorder format. This feature may be useful for limited trending of the switch/transmitter.

- Notes:**
1. To communicate with your Kayden CLASSIC 800, you will require an RS-485 adapter such as the Kayden SCA.
  2. Additional copies or the latest revision of the RCM Software may be downloaded at our website, [kayden.com](http://kayden.com), or call Kayden at (403) 253-1423.

**RS-485 Remote Communications**

The RS-485 remote communications port is connected as follows:

- 485 (C)** The common ground reference used on some three wire half-duplex systems. While no current should pass through this conductor, it should not be used as a shield. If using a shield it should only be connected to ground at one point, usually at the PLC or computer.
- 485 (A-)** The A or negative data line.
- 485 (B+)** The B or positive data line.
- 485 (T)** This pin provides an AC coupled terminator of 120 ohms when shorted to 485 (A-). This feature eliminates the need to add an external terminator. It is AC coupled to reduce power consumption when the 485 bus is idle. For more details on AC vs. DC termination of RS-485 networks, contact Kayden technical support at kayden.com.

**Notes:** For more information see Figures 11 & 12.

**Converters / Adapters - USB to RS-232 & RS-232 to RS-485**

**USB to RS-232 (DB-9) Adapter**

Adapts the Kayden SCA to USB for computers without a serial port.

**Part Number: A15-322**



**RS-232 (DB-9) to RS-485 Adapter**

The SCA is an RS-232 to RS-485 adapter for Modbus communication protocol. The SCA derives power from the Kayden switch.

**Part Number A15-321**



**USB to RS-485 Adapter**

Combines functions of USB to DB-9 and DB-9 to RS-485. Driverless functionality with newer operating systems.

**Part Number A15-323**



**Communication Cable**

**Communication Cable** is used to connect the SCA (Serial Communication Adapter) to the switch.

Standard Lengths: 4, 8 & 10 feet.

- Part Number: A05-CC-0004** 4 feet
- A05-CC-0008** 8 feet
- A05-CC-0010** 10 feet



These items can be purchased separately but are required to use the Kayden RCM software.

## 4

## Quick Setup Guide

## Mechanical Installation

NOTE: Observe the following safety guidelines before installing or removing your CLASSIC switch/transmitter:

- Use proper eye protection and any other safety equipment as required by your installation site.
  - Check electrical power to ensure that all power has been disconnected and “locked out.”
  - Ensure the process tank or line pressures are “zero.”
  - Protect yourself against accidental release of steam, hot water, acids and other potentially hazardous media.
  - Follow all safety precautions as specified for your installation site and local codes.
1. Before installing your CLASSIC, coat the sensor threads with plant-approved lubricant or sealant to prevent threads from binding.
  2. Extra caution should be taken not to over-tighten the sensor threads while installing.
  3. Install the CLASSIC, taking into account the orientation of the sensor as described below.
  4. Keep in mind the need for easy access, safety of personnel and a suitable environment for the CLASSIC. In general, install the CLASSIC so as to minimize its exposure to vibration, shock, and extreme temperature fluctuations.

## Sensor Orientation

The CLASSIC sensor is marked with the universal symbol . This surface should be flat up and level in a horizontal flow application only. Refer to **Figures 1** and **2** for flow and level applications; this surface of the hex should be parallel to the direction of change in the process.

**Figure 1 -  
Sensor Orientation for  
Horizontal Flow**

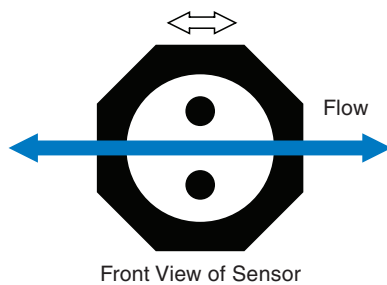

**Horizontal Pipe: Side Mount**

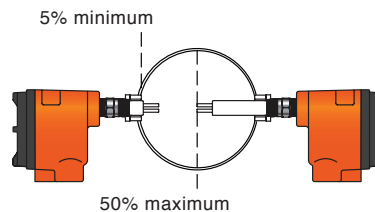

**Top/Bottom  
Mount**

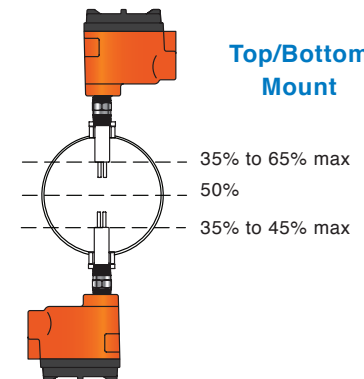

**Figure 2 -  
Sensor Orientation for Vertical  
Flow**

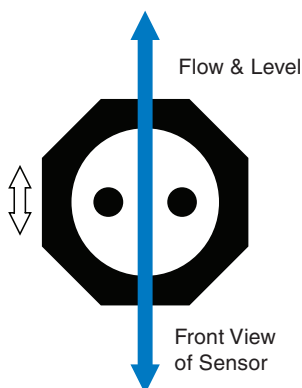

**Sensor Positioning,  
Horizontal Pipe**

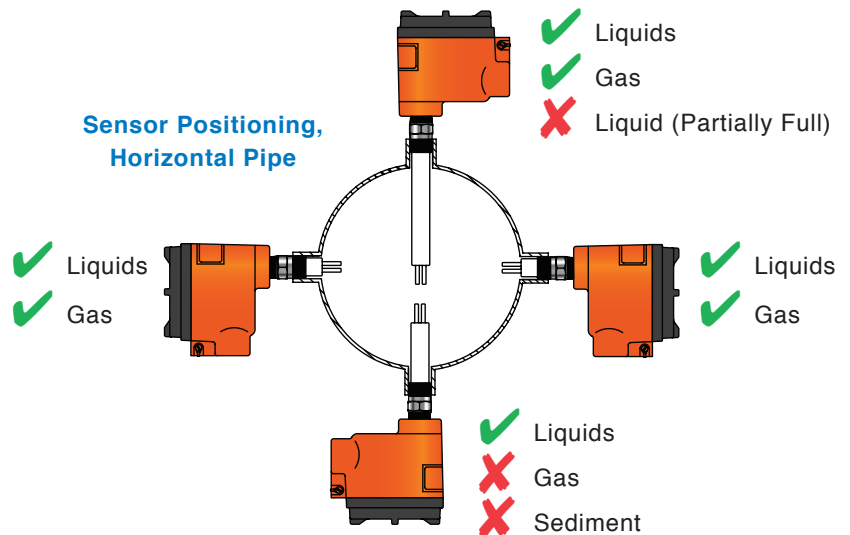

# KAYDEN | Quick Setup Guide

## CLASSIC™ 800

To configure or adjust the CLASSIC, perform the steps in the order indicated by 1 - 4

- Perform steps 1 & 2.
- Push RUN and verify Thermal Signal in your Flow/Level operating condition.
- Push SET and perform steps 3 & 4.

\*If Relay 2 is not being used it is useful to configure the settings for Relay 2 exactly the same as Relay 1.

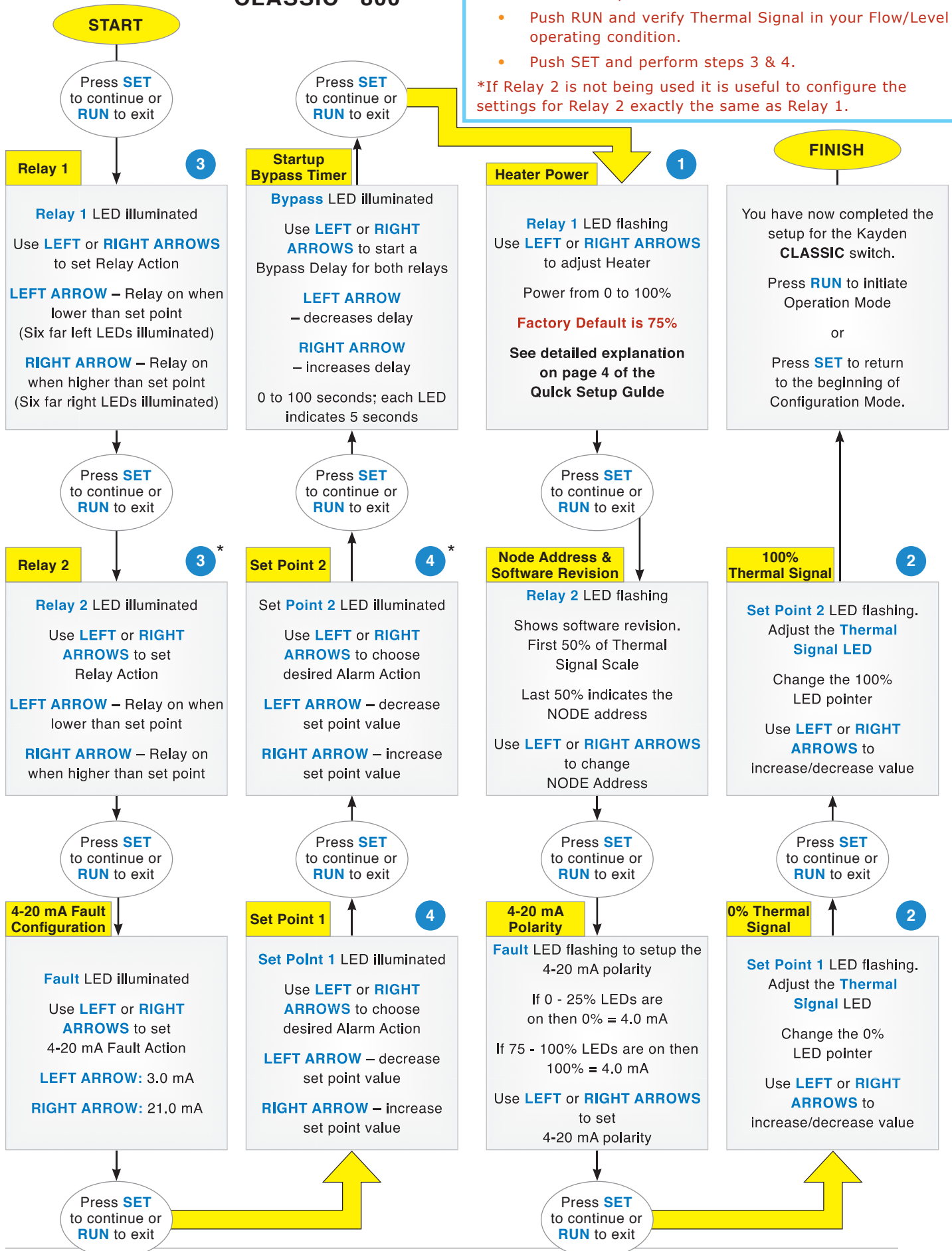



CLASSIC 800 Display Panel

Display Panel Indicators:

- Relay 1** On steady when Relay 1 is energized
- Relay 2** On steady when Relay 2 is energized
- Fault** Indicates a self-test error or fault condition
- Set Point 1** On steady when viewing Set Point 1
- Set Point 2** On steady when viewing Set Point 2
- Run Mode** Flashing when switch is operating
- Bypass** Flashing when the Start-up Bypass Timer is active
- Thermal Signal** Displays Thermal Signal

The Thermal Signal increases as:

- Flow** The flow rate increases
- Level** The sensor is submerged
- Interface** The sensor is submerged by the second liquid of greater thermal conductivity

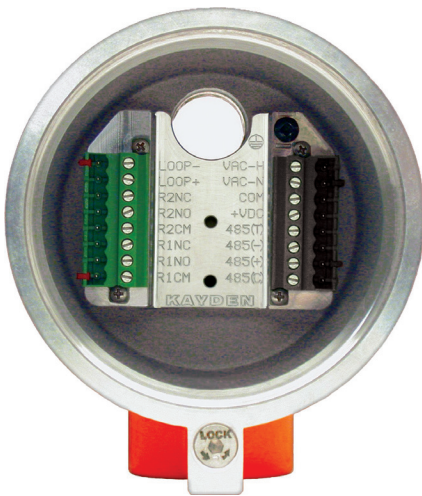

Mounting Base Plate / Terminal Assembly

Mounting Base Plate Wire Positions	
LOOP -	VAC-H
LOOP +	VAC-N
R2NC	COM
R2NO	+VDC
R2CM	485-T
R1NC	485-A (-)
R1NO	485-B (+)
R1CM	485-C

**RUN MODE - Run Mode LED is 'Flashing'**

<b>RUN</b>	Press and hold to view the <b>Software Revision</b> and <b>Node Address</b>
<b>SET</b>	Press and release to enter <b>Set Mode</b> (see table below)
<b>Left Arrow</b>	Press and hold to view the LED-0 and LED-100 Pointers on Baseline graph
<b>Right Arrow</b>	Press and hold to view Thermal Signal data on Baseline Graph
<b>1</b>	Press and hold to view <b>Set Point 1</b> on Scaled Bar Graph View
<b>2</b>	Press and hold to view <b>Set Point 2</b> on Scaled Bar Graph View

**SET MODE - Run Mode LED is 'Off'**

<b>RUN</b>	Press and release to exit <b>Set Mode</b> and return to <b>Run Mode</b>
<b>SET</b>	Press and release to proceed to next step of <b>Set Mode</b>
<b>Left Arrow</b>	Adjust selection as per <b>Set Mode</b> function
<b>Right Arrow</b>	Adjust selection as per <b>Set Mode</b> function
<b>1</b>	No function in <b>Set Mode</b>
<b>2</b>	No function in <b>Set Mode</b>

**CAUTION**

Installation, connection and maintenance must be carried out by expert technicians who have read these operating instructions. These operating instructions include all-important information required for the installation and operation of this product. They supplement the full Product Manual, and the relevant national regulations with respect to the equipment as well as with the maintenance activities.



**POWER, AC/DC**

Either AC or DC voltage can be used to power the CLASSIC:

- For AC power, connect the HOT line to VAC-H, the NEUTRAL to VAC-N and the GROUND wire to the green grounding screw, also indicated by the ground symbol.
- For DC Power, connect the positive voltage to +VDC and the common or negative to COM.

CAUTION

Never power on the circuits in a potentially explosive area without first installing the enclosure cover.

Always lock the cover in place. This may be required by your local safety or electrical code.

<b>RELAY OUTPUTS</b>	
The CLASSIC features two independent set points each with its own mechanical relay for output. The connections for the contacts of these relays are:	
<b>R1COM</b>	Common or pole contact for Relay 1
<b>R1NC</b>	Normally closed contact for Relay 1 when the coil is not energized
<b>R1NO</b>	Normally open contact for Relay 1 when the coil is not energized
<b>R2COM</b>	Common or pole contact for Relay 2
<b>R2NC</b>	Normally closed contact for Relay 2 when the coil is not energized
<b>R2NO</b>	Normally open contact for Relay 2 when the coil is not energized

**NOTE:** For fail-safe installations, the desirable relay state is usually energized and the circuit closed. Use the normally open contacts for fail-safe installations since they are closed when the relay is energized.

**MAINTENANCE**

Your Kayden instrument requires very little maintenance as there are no moving parts.

Without detailed knowledge of the environment parameters of the application surroundings and process data media, Telematic cannot make specific recommendations for periodic inspection, cleaning, or testing procedures. Telematic does however suggest

general guidelines for maintenance (see the CLASSIC Product Manual). Use operating experience to establish the frequency of each type of maintenance.

**CALIBRATION**

The CLASSIC does not require any calibration for use as a switch/transmitter. Once properly setup, the CLASSIC will be as stable and repeatable as the process in which it is installed. It may be necessary to check or repeat the setup procedure if the process changes dramatically over time.

**HEATER POWER**

The CLASSIC uses a 2-watt heater that can be set between 0 - 100%, in 5% increments.

- Since the energy added by the heater is used in determining the Thermal Signal, altering the amount of heat changes the Thermal Signal.
- If the heater power is changed more than 5% (1 LED) this may require the 0% & 100% Thermal Signal to be similarly adjusted in order not to lose sensitivity and reaction time.
- The Factory Default Heater Power setting of 75% (1.5 watts) is suitable for most Flow applications with Hydro-carbons.
- GUIDELINES FOR SETTING HEATER POWER:
  - **30 - 60% heater power (7-13 LEDs)** - Air or Gas (Flow) (depending on velocity)
  - **60 - 75% heater power (13-16 LEDs)** - Oil or Hydrocarbon based liquids (Flow, Level & Interface)
  - **80 - 100% heater power (17-21 LEDs)** - Water or non-viscous liquids (Flow, Level & Interface)

The faster the flow rate (velocity) the more heat is required. In level applications the amount of heat, in part, determines the reaction time.

The CLASSIC 800 Series has a “Smart Heater” function (see the “**Classic 800 Product Manual**”). If a heater operates constantly in a no flow or dry condition, a “Thermal Offset” can occur. This means the heater may affect the reading from the reference RTD. The microprocessor will automatically reduce the heater power setting to a lower power rating when the probe is “dry” or in a “no-flow” condition. When the process media touches the sensors, or flow begins again, the original heater power setting is restored.

**KAYDEN**<sup>®</sup>  
**Helping the World Switch**<sup>™</sup>

Kayden Instruments  
 3364-114th Avenue S.E. Calgary, Alberta, Canada T2Z 3V6  
**Tel:** (403) 253-1423 **Fax:** (403) 255-0042 **Web:** kayden.com  
 DOC#: QG-800-004 **Effective: February 2018** Supercedes: July 2017  
 QG-800-004-[010]  
 This is a Controlled Document and cannot be changed without the Approval of the Quality Control Manager.



## 5

## Maintenance

## I. GENERAL INFORMATION

With proper installation the CLASSIC 800 will require very little maintenance, as there are no moving parts subject to wear. Following a few simple guidelines will ensure years of dependable service.

### 1. Cover

In accordance with CSA, FM, UL and local codes the cover must be properly installed at all times. The threads of the cover should be lightly coated with a lubricating compound to prevent seizing, freezing and corrosion. Spray lubricants are not recommended.

### 2. Process and Conduit Connections

- In accordance with CSA, FM and local codes all power and communication wiring should be enclosed either in conduit or an approved jacketed cable. Ensure that the electrical connection made at the enclosure of the CLASSIC 800 meets all codes and requirements.
- As described in detail in Section 2 “Installation Guidelines”, ensure that the sensor is installed with the proper orientation, to the proper depth and coat threads with a thin layer of thread tape or sealant/lubricant.
- Most Fault conditions and reported “failures” are actually caused by loose, broken or improper electrical connections. Ensure that the connections for the sensor, input power and relay output are correct and secure.

### 3. Sensing Elements

- The alloy (Stainless Steel, Titanium, Hastelloy, etc.) sensors require no periodic maintenance, but any deposits or scaling should be removed from the sensor tip as necessary. Use the appropriate cleaning device or material relative to your process (example: cloth, brush, wire brush, steel wool, sandpaper, water, detergent, compatible solvents to the sensor material, etc.).

**Notes:** As described in detail in Section 2 “Installation Guidelines”, proper physical installation of the sensor is critical to the operation of the switch/transmitter in terms of sensitivity and response time. Because sediment will collect at the bottom of any vessel, and entrained gases will always collect at the top of any vessel, ensure sensing tip is inserted to a point where it will be constantly and fully exposed to the desired process media. Avoid locations where sediment may accumulate and eventually isolate the sensing tip from the process.

#### 4. Electronics Module

- Proper ESD (electrostatic discharge) procedures should be observed when handling the Electronics Module.
- A remote electronics enclosure system is required when ambient temperatures exceed 65°C (149°F) where the electronics will be mounted. The combination of several factors relative to temperature should be considered when mounting the switch/transmitter:
  - A. High temperatures of the process material, which may over time, become a convective heat source.
  - B. High ambient temperature, which may prevent the surrounding air from cooling or insulating the electronics.
  - C. Radiant heat, if the switch/transmitter is installed in direct sun in a hot climate, or near a heat source.
  - D. Mechanical features of the installation such as pipe insulation, heat sinks, cooling fans, etc.



## 5. Adjustment & “Calibration”

The CLASSIC 800 is a digital flow, level, interface and temperature switch/transmitter and is built to require minimal maintenance and no calibration beyond proper installation and setup.

- The Kayden Electronics Modules are completely digital and have no moving parts or mechanical trim pots that could be effected by vibration or high unit cycles.
- True temperature compensation is programmed into the firmware and is continuously factored into the operation algorithms of the microprocessor.
- The heater is a separate element from the sensors and is itself directly controlled by the microprocessor.

Therefore, once properly setup, the CLASSIC 800 will be as stable and repeatable as the process in which it is installed. For instance should the application change from Flow to Level or the media change from Hydrocarbon to Water-based or the Flow Rate increase or decrease significantly it may be necessary to check and/or change the setup parameters (Range, Heater Power, Set Point).

## 6. Using the Kayden RCM Software to Satisfy Preventative Maintenance Requirements

One feature of the Kayden RCM Software\* is the Configuration function which automatically stores all setup information and displays it on the Configuration screen within the software whenever the CLASSIC 800 is connected to a PC. This information may be named, stored and emailed as a file to preserve all operation setup parameters.

Therefore, the user may construct “Maintenance Only Setup Parameters” with a slightly different heater setting and set point and save these as a file. This Maintenance Setup File could then be loaded in place of the normal operating setup which will cause the display and relay function to change accordingly. Once this change is observed the normal setup can be reloaded and the preventative maintenance requirement satisfied.

\*The Kayden RCM Software is available upon request, at no charge on CD, when a new CLASSIC 800 is purchased. Additional copies may be obtained at no charge from [kayden.com](http://kayden.com). In addition to the software you will need the SCA Serial Communication Adapter, the USB to Serial converter and communication cable. These can be ordered online at [kayden.com](http://kayden.com).

## 6

## Binary Table

The following information refers to **Section 3, Point 5, “View or Adjust the Node Address & View the Software Revision”**.

The **Software Revision** and **Node Address** are displayed on the **Thermal Signal Bar Graph** as two binary bytes. The **Software Revision** is not adjustable but can be useful should telephone support be required. **The Factory Default for the Node Address is 1.**

**Decimal to Binary Table:** An ‘OFF’ LED represents 1 while an ‘ON’ LED represents 0.

*1	0	00000000	16	00010000	32	00100000	48	00110000
	1	00000001	17	00010001	33	00100001	49	00110001
	2	00000010	18	00010010	34	00100010	50	00110010
	3	00000011	19	00010011	35	00100011	51	00110011
	4	00000100	20	00010100	36	00100100	52	00110100
	5	00000101	21	00010101	37	00100101	53	00110101
	6	00000110	22	00010110	38	00100110	54	00110110
	7	00000111	23	00010111	39	00100111	55	00110111
	8	00001000	24	00011000	40	00101000	56	00111000
	9	00001001	25	00011001	41	00101001	57	00111001
	10	00001010	26	00011010	42	00101010	58	00111010
	11	00001011	27	00011011	43	00101011	59	00111011
	12	00001100	28	00011100	44	00101100	60	00111100
	13	00001101	29	00011101	45	00101101	61	00111101
	14	00001110	30	00011110	46	00101110	62	00111110
	15	00001111	31	00011111	47	00101111	63	00111111
							↓	
							247	11111111

\*1 Not valid, only used for broadcast commands.

# 7

## Troubleshooting

### LED Fault Indicator

The **CLASSIC 800** is designed so that any error condition will be immediately detected and displayed as a **FAULT** condition on the Display Panel.

- The diagnostic circuit continuously monitors the operation of the heater, sensor elements, connecting pathways and all the aspects of the Electronics Module.
- To prevent any possibility of an intermittent **FAULT** the **FAULT** Code remains until the problem is corrected.
- When in **FAULT** MODE both relays will de-energize and remain de-energized.
- The **4-20 mA** output can be programmed to revert to a value of either **3.0 mA** or **21 mA** to indicate **FAULT** mode. For more information see **Section 2 “Installation Guidelines, View or Adjust the 4-20 mA Fault Mode Configuration”**.
- All **FAULT** Codes are automatically recorded in the **EVENT LOG**. The **EVENT LOG** may be viewed by in the Kayden RCM Software.

In the event a **FAULT** occurs, the Display Panel will display a **FAULT** LED. If the unit enters **FAULT** MODE one of the following will be displayed:

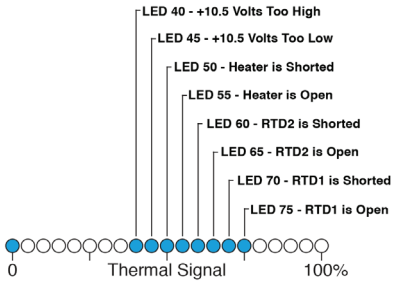
Fault Condition	Cause	Display Panel	Solution
0 (far left) LED & 1, 2 or 3 of 40 - 75% (center) LEDs <b>ON</b> (not flashing)	<p><b>Self-Test Error</b></p> <p>This condition may be caused by an error in the Electronics Module, internal connections, external wiring or the sensor itself.</p>	<p>Various combinations of LEDs as per below:</p> 	<p>Disconnect the Electronics Module and test the sensor wiring (see Figure 24).</p> <p>If the wiring resistance values are correct, the <b>FAULT</b> may be in the Electronics Module. The Electronics Module should be returned to the factory for testing and repair.</p> <p>If the wiring resistance values are incorrect the sensor should be returned for testing and repair.</p>

- Note:** \*In **FAULT** Mode the **CLASSIC 800** display cycles between:
- Fault indication as described above
  - Firmware Revision and Node Address (Unit #).

### How to Reset the CLASSIC Factory Settings

To reset the CLASSIC to factory default settings press the following 3 buttons:

- **LEFT ARROW - RIGHT ARROW - RUN** simultaneously until all LED's flash.
- A successful reset will be indicated by five consecutives flashes of all LEDs followed by a pause and two more flash.
- **Warning:** All configuration changes will be lost and the unit set back to the factory defaults
- Should not be performed without consulting Kayden Technical Support

Resistance Values for Sensor Wiring			
Wire Colour	Ohms	Wire Colour	Ohms
Red to Red	50	Black to White	1100*
Blue to Blue	0	Red to any other lead	Infinite
Black to Black	0	Blue to Black	Infinite
Blue to Yellow	1100*		

\*Exact value depends on the temperature of the probe tips

**Figure 24 - Resistance Wiring**

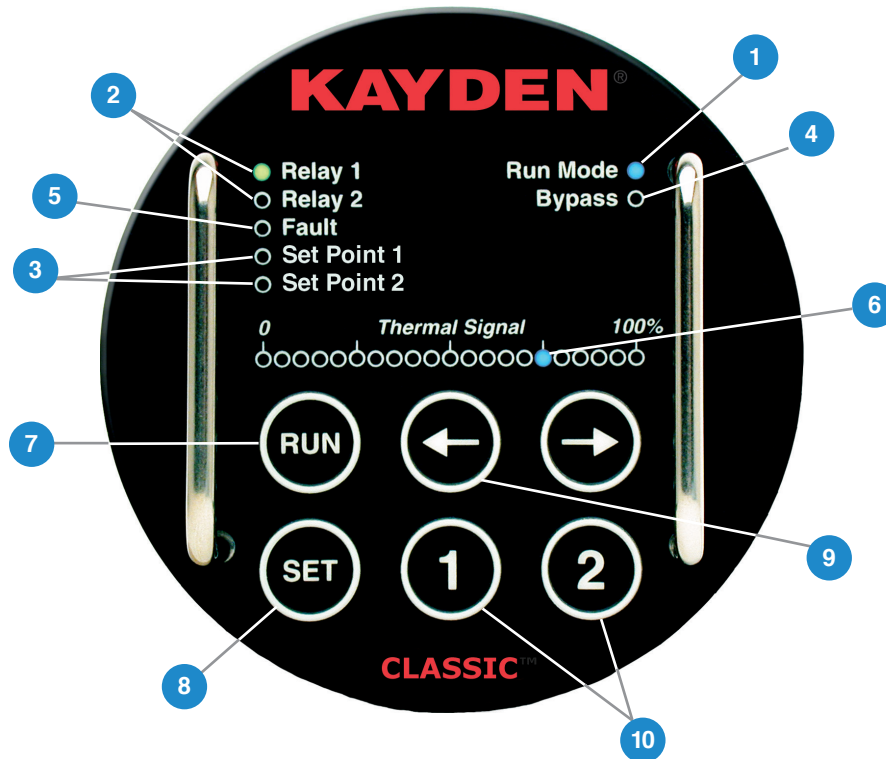

Figure 25 - Display Panel Indicators

1. **Run Mode:** Flashing LED indicates normal operation.
2. **Relay 1, Relay 2:** Solid LED indicates energized relay contact.
3. **Set Point 1, Set Point 2:** Solid when displaying the associated set point. (e.g. press and hold 1.) Blinking LED when a set point has been passed but relay response is delayed by an active timer
4. **Bypass:** Indicates that the Start-up Bypass Timer feature is currently enabled.
5. **Fault:** Indicates that the switch/transmitter is in Fault Mode when solid or Fault Recovery Mode when blinking. (See Fault Recovery Timer.)
6. **Thermal Signal Bar Graph:** Displays the Thermal Signal (rate of Thermal Dispersion by default) which represents the process condition (Flow, Level) as determined by the setup. Other values may be displayed depending on mode.
7. **RUN:** In RUN Mode pushing the RUN button changes the display from process condition to the Node Address and the Firmware revision. In Setup Mode pushing the RUN button returns the switch/transmitter to RUN Mode.
8. **SET:** Places the unit in Setup Mode unless locked by the Kayden RCM Software.
9. **Left Arrow:** In Setup Mode the Left Arrow reduces (moves the value to the left or towards 0). In RUN Mode pushing and holding the Left Arrow button will display the Baseline View (unscaled view).
10. **1, 2:** Pushing and holding 1 or 2 will display Set Point 1 or Set Point 2 accordingly as programmed.

## Return of Material

To expedite the return process, call Kayden in Canada at (403) 253-1423 or internationally at 011 403-253-1423. You will be asked for product model and serial numbers, and be provided an RMA (Return Material Authorization) number.

## Hazardous Materials

Kayden does not accept the return of Products that are contaminated with any hazardous material. It is solely the Customers responsibility to ensure any and all items returned to Kayden have been thoroughly and completely decontaminated.

## Service, Technical Support & Contact Information

Kayden provides full in-house technical support 8 a.m. to 5 p.m. MST (Mountain Standard Time), Monday through Friday (except holidays).

**Web:** [kayden.com](http://kayden.com)

**E-mail:** [info@kayden.com](mailto:info@kayden.com)

**Mail:** Kayden Instruments  
3364-14th Avenue S.E.  
Calgary, Alberta, Canada T2Z 3V6

**Your Local Distributor:** To locate your local Distributor please visit [kayden.com](http://kayden.com).

## 8

## Glossary

<b>Active RTD</b>	The active RTD detects and outputs a signal to the Electronics Module which is proportionate to the process media temperature plus heat added by the heater.
<b>Bypass</b>	Indicates the unit is in “Start-up Bypass Mode”, which forces both relays to be energized for the duration of the Start-up Bypass Timer.
<b>Fault</b>	Indicates a self-test error (call Technical Support for further information).
<b>Heater</b>	The part of the sensing element that heats the active RTD.
<b>Interface</b>	The point where two different processes meet (as in oil & water).
<b>LED</b>	Light Emitting Diode
<b>Local Enclosure</b>	The enclosure attached to the sensing element. (Normally contains the Electronics Module).
<b>Mounting Base Plate</b>	Connection for CLASSIC 800 series Electronics Module and Terminal Wiring Assembly
<b>Reference RTD</b>	The Reference RTD detects and outputs a signal to the Electronics Module which is proportionate to the process media temperature.
<b>Relay 1</b>	Indicates Relay 1’s coil is energized.
<b>Relay 2</b>	Indicates Relay 2’s coil is energized.
<b>Remote Enclosure</b>	Enclosure for the Electronics Module. Used when the Electronics Module must be located away from the sensing element (extreme heat, vibration, convenience etc.).
<b>RCM, RCMS</b>	Kayden Remote Control & Monitoring Software provides a graphical computer interface for the CLASSIC series.
<b>RTD</b>	Resistance Temperature Detector; a sensor whose resistance varies with temperature changes.
<b>Run Mode</b>	Indicates normal operation when flashing.
<b>Set Point 1</b>	Indicates when the Thermal Signal Bar Graph is displaying the value of Set Point 1.
<b>Set Point 2</b>	Indicates when the Thermal Signal Bar Graph is displaying the value of Set Point 2.
<b>Thermal Offset</b>	Thermal convection
<b>Thermal Signal</b>	The amount of thermal energy dissipated from the Active RTD by the process.

**A**

**Outline Dimensional Drawings**

**CLASSIC™ 810, 812 & 828**

Inches (cm)

**CLASSIC™ 810 Threaded**

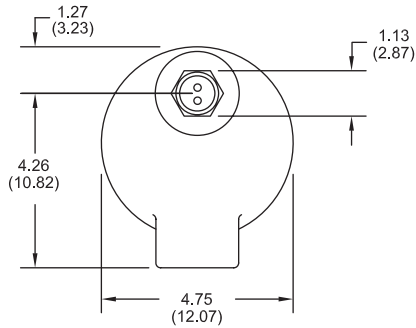

	Inches	cm
RAE	1.05	2.66
RAD	0.90	2.29
RAC	0.69	1.75

For dimensions on all process connections go to [kayden.com](http://kayden.com)

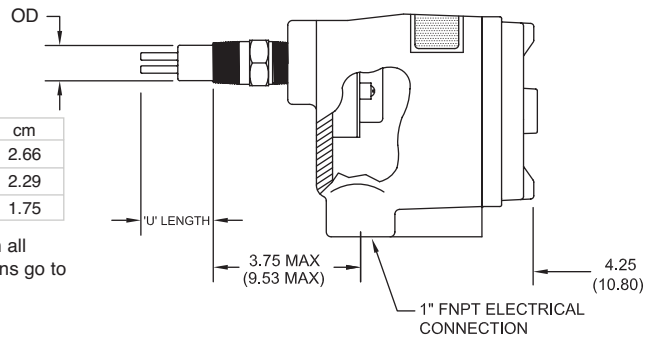

**CLASSIC™ 812 Flanged**

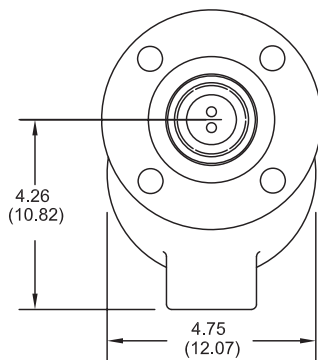

DEPENDENT ON FLANGE SIZE  
1.05" or 0.84"  
2.67 cm or 2.13 cm

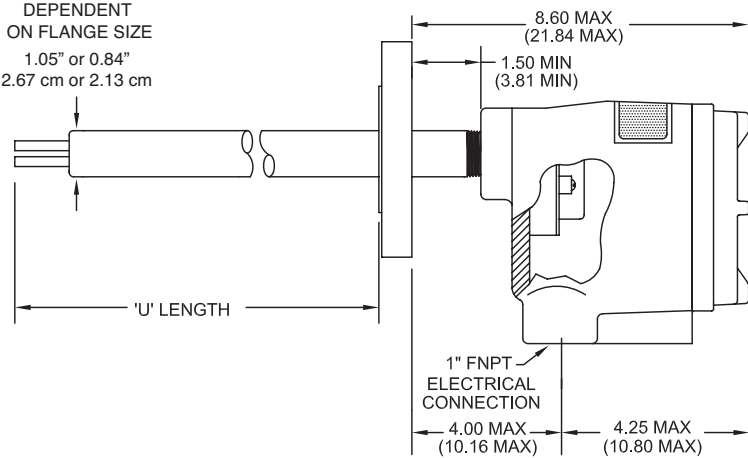

**CLASSIC™ 828 Sanitary Flanged**

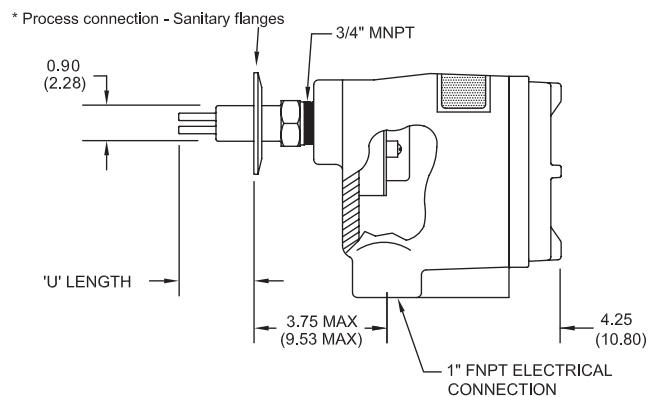
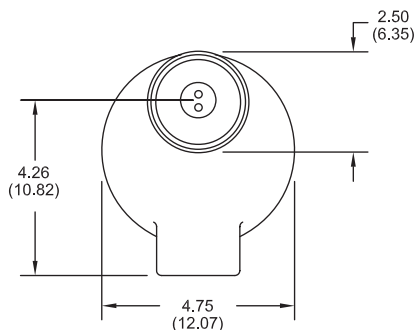

\* Process connection - Sanitary flanges



**CLASSIC™ 830**

Inches (cm)

**CLASSIC™ 830 InLine Threaded (Horizontal)**

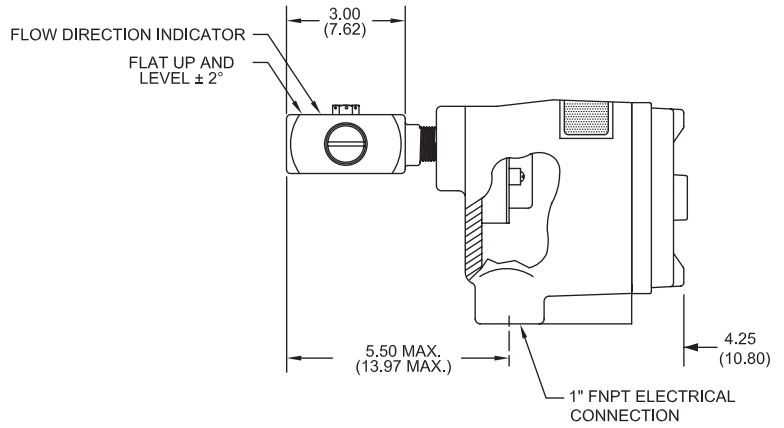
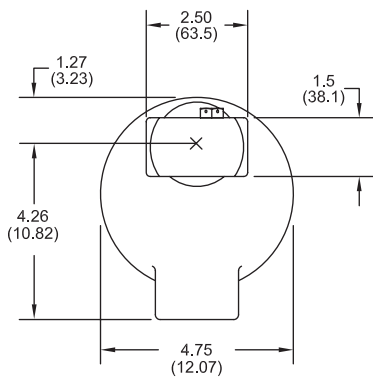

**CLASSIC™ 830 InLine Threaded (Vertical)**

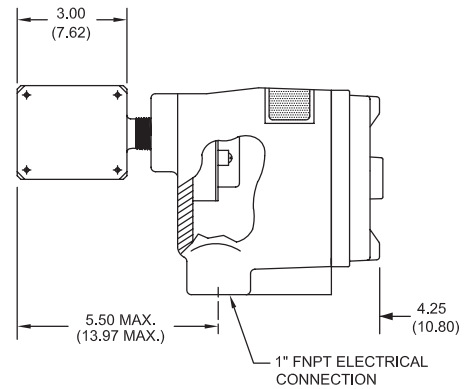
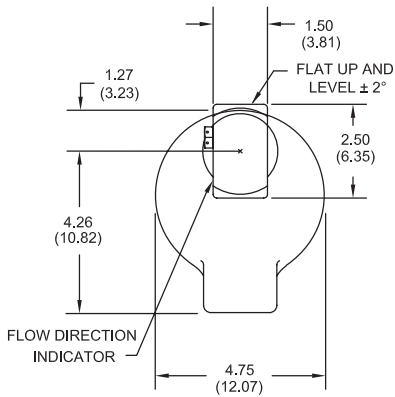

CLASSIC™ 832 & 816

Inches (cm)

CLASSIC™ 832 InLine Flanged (Horizontal)

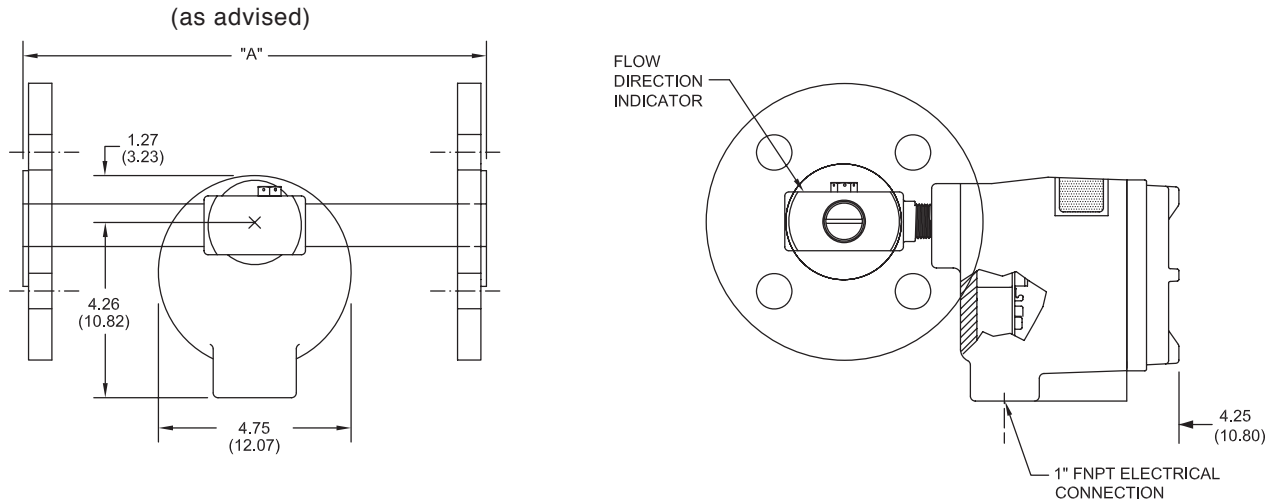

CLASSIC™ 832 InLine Flanged (Vertical)

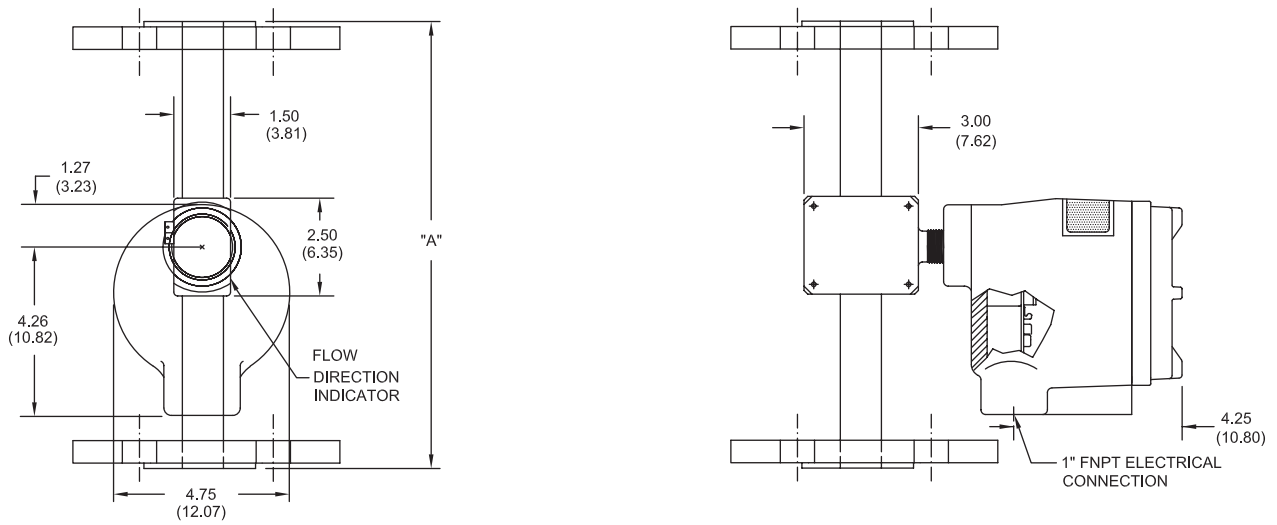

CLASSIC™ 816 Retractable Packing Gland Threaded - 1" MNPT - to 50 psi

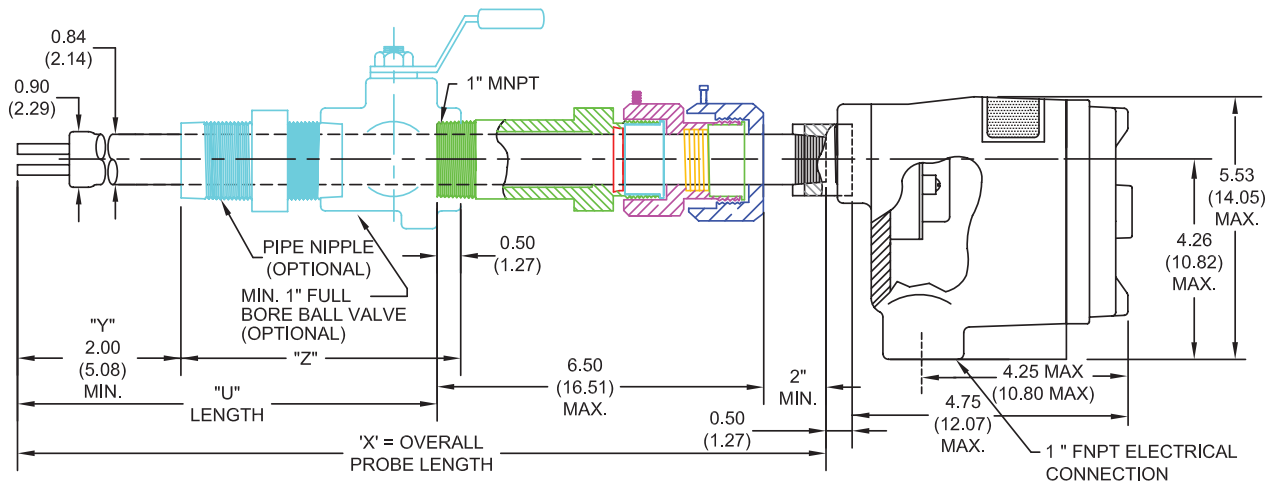

CLASSIC™ 816 & 814

Inches (cm)

CLASSIC™ 816 Retractable Packing Gland Threaded -  
1" MNPT - c/w Retaining Chain - to 125 psi

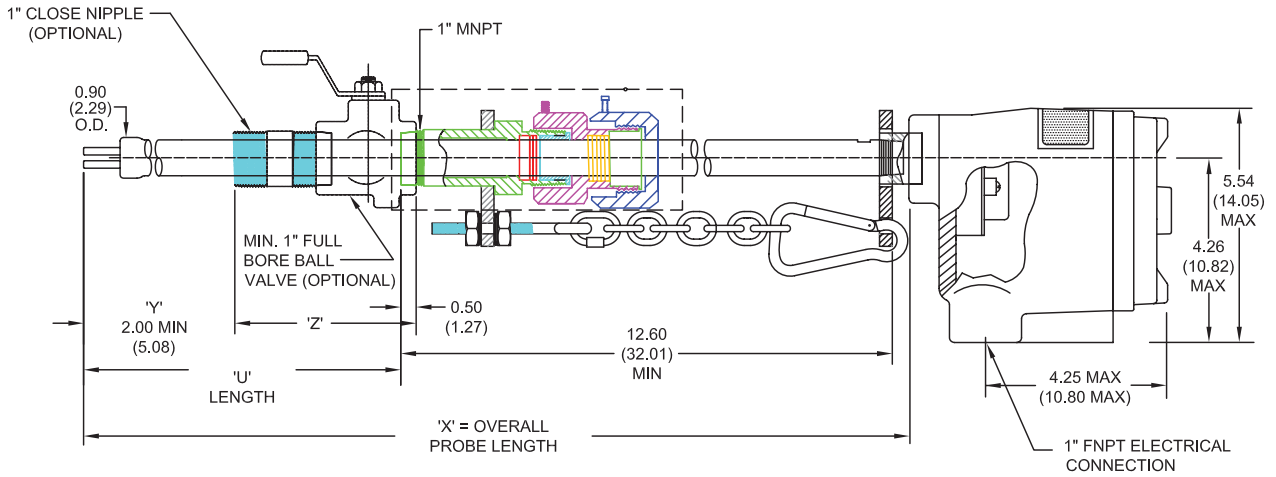

CLASSIC™ 816 Retractable Packing Gland Threaded - 1" MNPT - to 500 psi

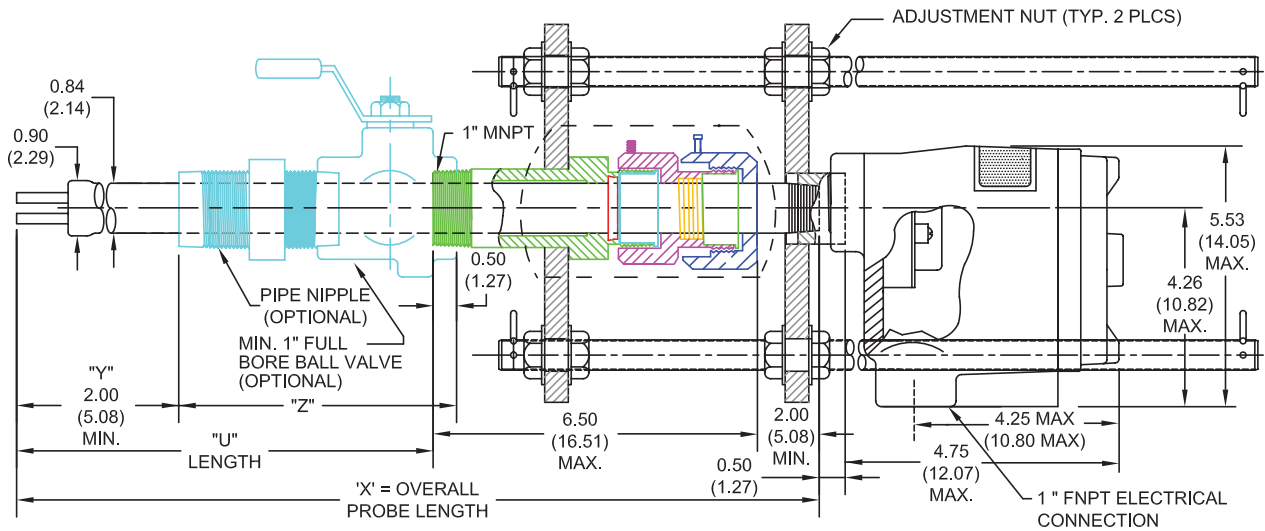

CLASSIC™ 814 Retractable Packing Gland Flanged - to 50 psi

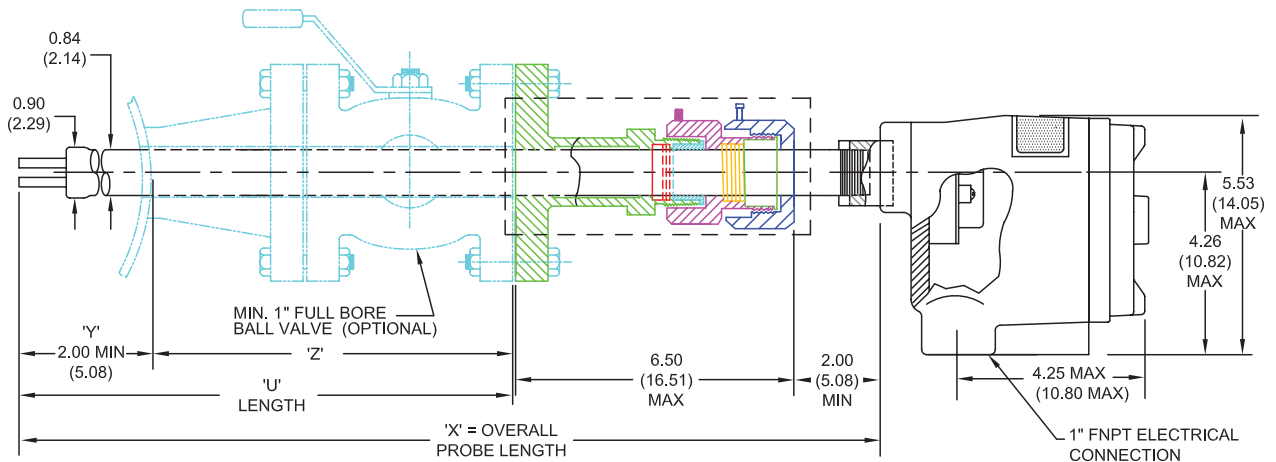

CLASSIC™ 814

Inches (cm)

CLASSIC™ 814 Retractable Packing Gland Threaded -  
1" MNPT - c/w Retaining Chain - to 125 psi

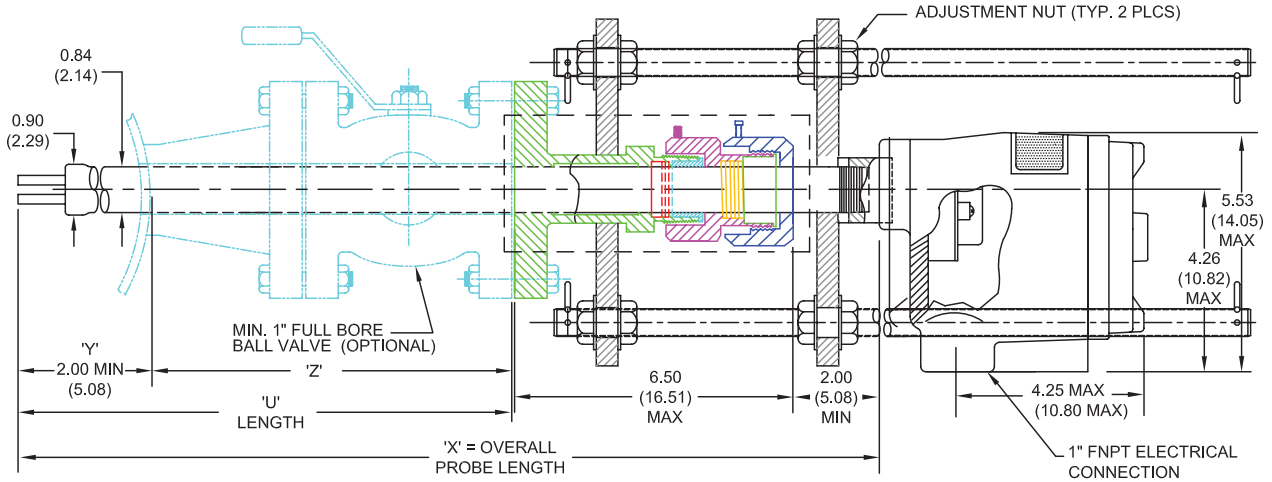

Remote Electronics Enclosure - Flameproof (CSA)

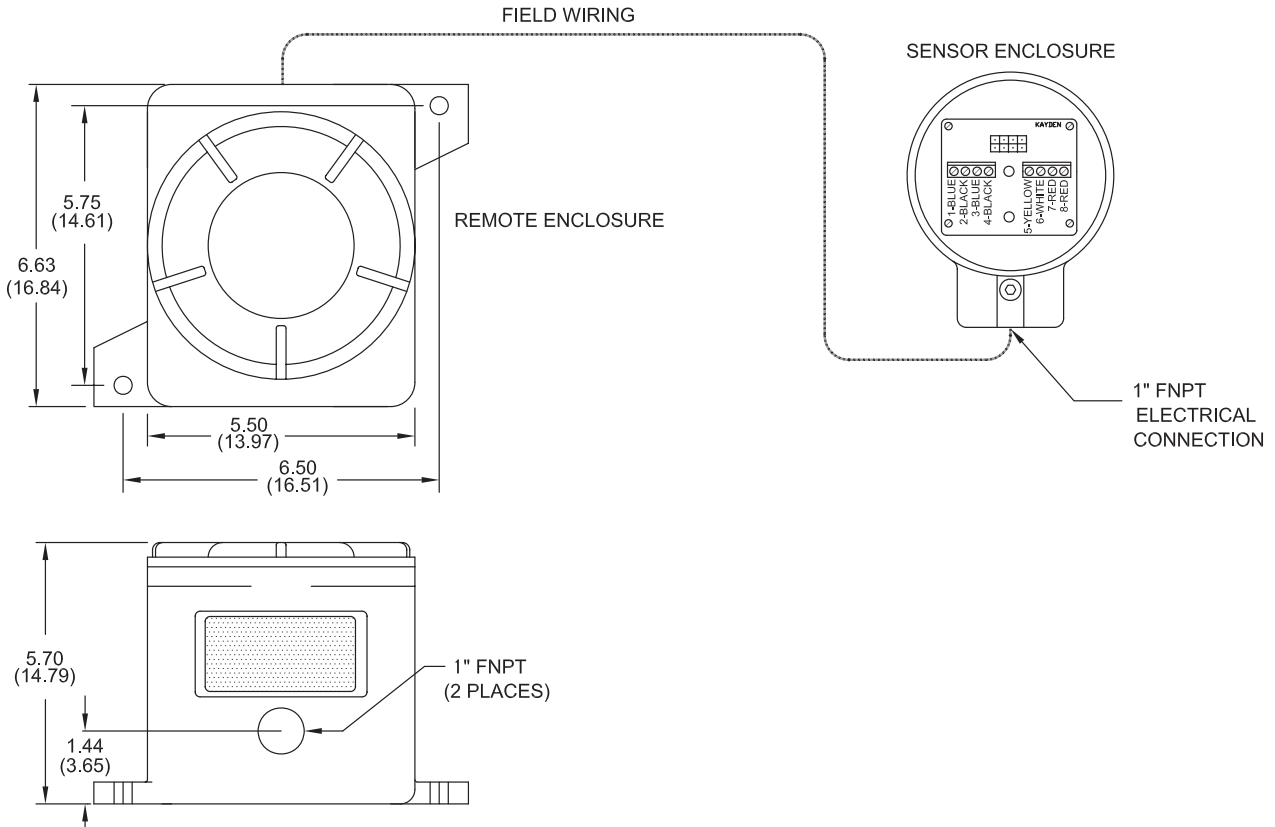

**Note:** Suitable for one (1) Electronics Module.

**Remote Electronics Enclosure - Flameproof (FM)**

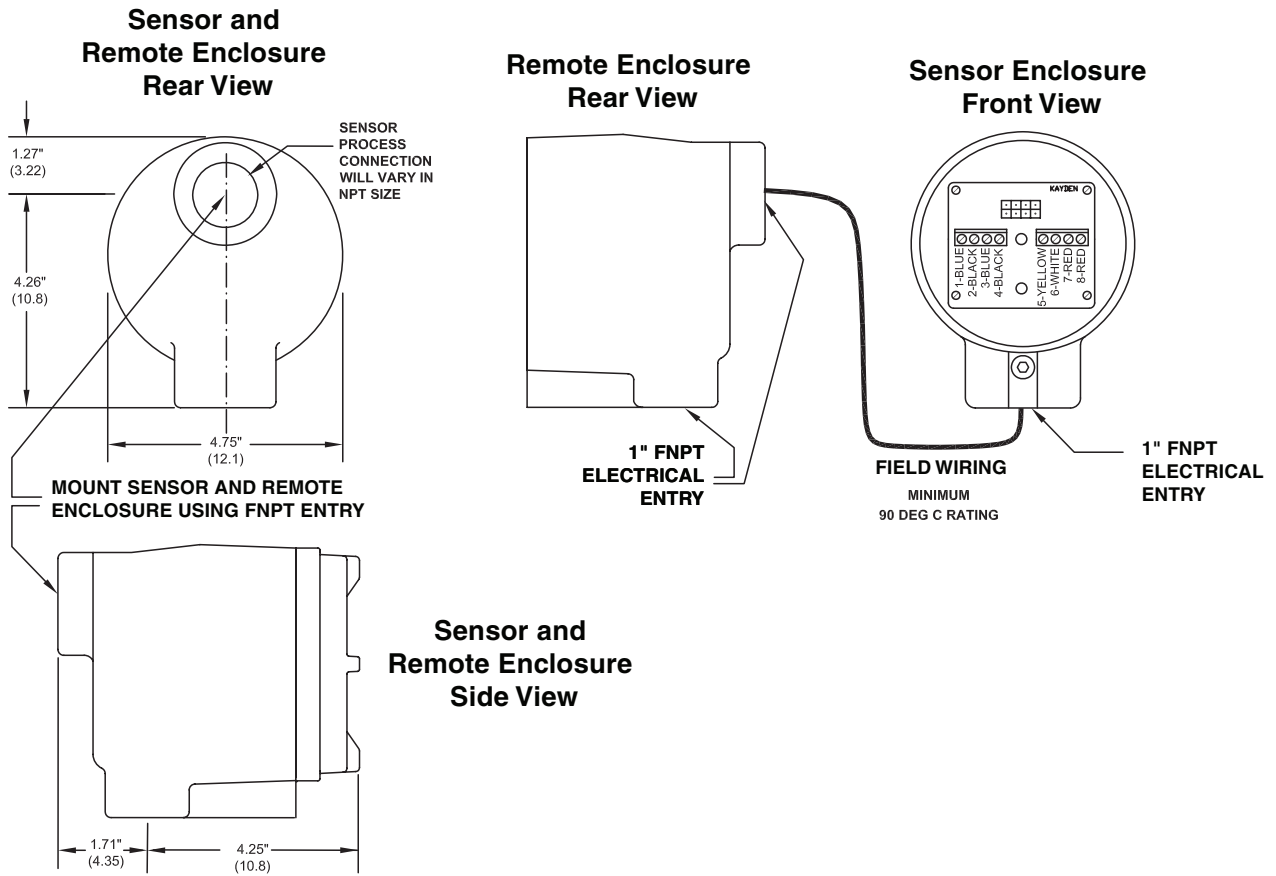

**Note:** Suitable for one (1) Electronics Module.

**Note:** For detailed drawings of all products visit [kayden.com](http://kayden.com)

## B

## Model Number Legends

To configure a Kayden CLASSIC please refer to [kayden.com](http://kayden.com) or your Kayden catalog. We have provided the following legends for configuring products. We have also provided Product Configurators on [kayden.com](http://kayden.com) for added ease of use.

Model Number Legends are available for the following **CLASSIC 800** Flameproof Models

**CLASSIC 810 Threaded**

- Insertion Style - 1/2", 3/4", 1", 1-1/4", 1-1/2" & 2" MNPT

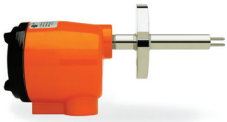
**CLASSIC 812 Flanged**

- Insertion Style - 1" ANSI 150 through 10" ANSI 900 Flanges

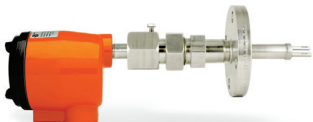
**CLASSIC 814 Flanged Retractable Packing Gland**

- Insertion Style - 1-1/2" through 10" ANSI 150 Flanges

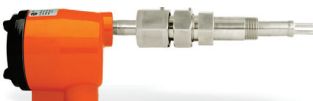
**CLASSIC 816 Threaded Retractable Packing Gland**

- Insertion Style - 1" MNPT

**CLASSIC 828 Sanitary Flanged**

- Insertion Style - 1", 1.5", 2", 2.5" & 3" Tri-Clamp® Flanges

**CLASSIC 830 Threaded**

- InLine Style - 3/4" FNPT

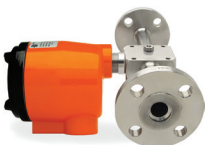
**CLASSIC 832 Flanged**

- InLine Style - 3/4" ANSI 150 through 10" ANSI 900 Flanges

<b>810</b>	<b>CODE</b>	<b>Sensor Type</b>								
	<b>R</b>	-45°C to +200°C (-50°F to +392°F) Continuous Service								
	<b>CODE</b>	<b>Sensor Material</b>								
	<b>A</b>	316/316L Stainless Steel								
	<b>X</b>	Titanium Gr. 2								
	<b>T</b>	Hastelloy C-276								
	<b>CODE</b>	<b>Process Connection - MNPT</b>								
	<b>C</b>	1/2"								
	<b>D</b>	3/4"								
	<b>E</b>	1"								
	<b>F</b>	1-1/4"								
	<b>G</b>	1-1/2"								
	<b>H</b>	2"								
	<b>CODE</b>	<b>Insertion 'U' Lengths</b>								
	<b>0012</b>	1.2" (3.0 cm)								
	<b>0020</b>	2" (5.0 cm)								
	<b>0030</b>	3" (7.5 cm)								
	<b>0040</b>	4" (10.1 cm)								
	<b>0060</b>	6" (15.2 cm)								
	<b>0090</b>	9" (23 cm)								
	<b>0120</b>	12" (30 cm)								
	<b>0180</b>	18" (46 cm)								
	<b>IXXXX</b>	Custom 'U' Lengths: Use 4 digits preceded by an 'I' (i.e. 3.5" 'U' = I0035) (Use 'M' for cm)								
	<b>CODE</b>	<b>Input Power</b>								
	<b>C</b>	12-24 VDC and 115-230 VAC, 50 to 60 Hz								
		<b>Electronics</b>								
		Microprocessor Controlled with User Interface.								
		Two SPDT sealed relay contacts. Modbus via RS-485. 4-20 mA current loop.								
	<b>CODE</b>	<b>Local Enclosure</b>								
	<b>1</b>	Flameproof - Aluminum								
	<b>CODE</b>	<b>Cover - For Local Enclosure</b>								
	<b>B</b>	Blind Cover - Flameproof								
	<b>G</b>	Glass Lens Cover - Flameproof								
	<b>CODE</b>	<b>Remote Electronics Enclosure &amp; Cover</b>								
	<b>0A</b>	Not Required								
	<b>1B</b>	Blind Cover - Flameproof								
	<b>1G</b>	Glass Lens Cover - Flameproof								
	<b>CODE</b>	<b>Agency Approvals</b>								
	<b>1</b>	UL & CSA								
	<b>3</b>	UL, CSA & CRN								
	<b>9</b>	FM								
	<b>CODE</b>	<b>Language</b>								
	<b>E</b>	English								
<b>810</b>	<b>R</b>	<b>A</b>	<b>D</b>	<b>0020</b>	<b>C</b>	<b>1</b>	<b>G</b>	<b>0A</b>	<b>9</b>	<b>E</b>



Flow, Level, Interface & Temperature Switch & Transmitter

Custom 'U' Lengths:  
2.5" - 120" (6.0 cm - 305 cm)  
Available in 1/2" (1.0 cm) increments.

© Kayden Instruments All rights reserved. Contents subject to change without notice.  
Please refer to kayden.com for current specifications and configurations.

Model Number Legend  
DOC#: ML-810-004

ML-810-004-[011]

This is a Controlled Document and cannot be changed without the Approval of the Quality Control Manager.

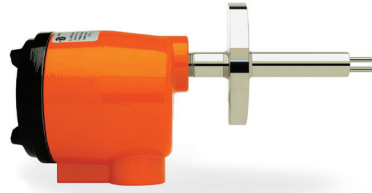

Flow, Level, Interface & Temperature Switch & Transmitter

<b>812</b>	<b>CODE</b>	<b>Sensor Type</b>																
	<b>R</b>	-45°C to +200°C (-50°F to +392°F) Continuous Service																
	<b>CODE</b>	<b>Sensor Material</b>																
	<b>A</b>	316/316L Stainless Steel																
	<b>X</b>	Titanium Gr. 2																
	<b>T</b>	Hastelloy C-276																
	<b>CODE</b>	<b>Process Connection - Flange Type</b>																
	<b>A</b>	Raised Face																
	<b>B</b>	RTJ - Ring Type Joint																
	<b>CODE</b>	<b>ANSI</b>	<b>CODE</b>	<b>ANSI</b>	<b>CODE</b>	<b>ANSI</b>	<b>CODE</b>	<b>ANSI</b>	<b>CODE</b>	<b>ANSI</b>	<b>CODE</b>	<b>ANSI</b>	<b>CODE</b>	<b>ANSI</b>	<b>CODE</b>	<b>ANSI</b>		
		<b>1"</b>	<b>1-1/2"</b>	<b>2"</b>	<b>3"</b>	<b>4"</b>	<b>5"</b>	<b>6"</b>	<b>8"</b>	<b>10"</b>								
	<b>121</b>	150	<b>131</b>	150	<b>141</b>	150	<b>151</b>	150	<b>161</b>	150	<b>171</b>	150	<b>181</b>	150	<b>191</b>	150	<b>201</b>	150
	<b>122</b>	300	<b>132</b>	300	<b>142</b>	300	<b>152</b>	300	<b>162</b>	300	<b>172</b>	300	<b>182</b>	300	<b>192</b>	300	<b>202</b>	300
	<b>123</b>	600	<b>133</b>	600	<b>143</b>	600	<b>153</b>	600	<b>163</b>	600	<b>173</b>	600	<b>183</b>	600	<b>193</b>	600	<b>203</b>	600
	<b>124</b>	900	<b>134</b>	900	<b>144</b>	900	<b>154</b>	900	<b>164</b>	900	<b>174</b>	900	<b>184</b>	900	<b>194</b>	900	<b>204</b>	900
			<b>CODE</b>	<b>Flange Material</b>														
			<b>A</b>	316/316L SST X Titanium Gr. 2														
			<b>T</b>	Hastelloy C-276														
			<b>CODE</b>	<b>Insertion 'U' Lengths 2.5" - 120" (6.4 cm - 305 cm) in 1/2" (1.0 cm) increments.</b>														
			<b>IXXXX</b>	Custom 'U' Lengths: Use 4 digits preceded by an 'I' (i.e. 3.5" 'U' = I0035) ('M' = cm)														
			<b>CODE</b>	<b>Input Power</b>														
			<b>C</b>	12-24 VDC and 115-230 VAC, 50 to 60 Hz														
				<b>Electronics</b>														
				Microprocessor Controlled with User Interface.														
				Two SPDT sealed relay contacts. Modbus via RS-485. 4-20 mA current loop.														
			<b>CODE</b>	<b>Local Enclosure</b>														
			<b>1</b>	Flameproof - Aluminum														
			<b>CODE</b>	<b>Cover - For Local Enclosure</b>														
			<b>B</b>	Blind Cover - Flameproof														
			<b>G</b>	Glass Lens Cover - Flameproof														
			<b>CODE</b>	<b>Remote Electronics Enclosure &amp; Cover</b>														
			<b>0A</b>	Not Required														
			<b>1B</b>	Blind Cover - Flameproof														
			<b>1G</b>	Glass Lens Cover - Flameproof														
			<b>CODE</b>	<b>Agency Approvals</b>														
			<b>1</b>	UL & CSA														
			<b>3</b>	UL, CRN & CSA														
			<b>9</b>	FM														
			<b>CODE</b>	<b>Language</b>														
			<b>E</b>	English														
<b>812</b>	<b>R</b>	<b>A</b>	<b>A</b>	<b>131</b>	<b>A</b>	<b>I0035</b>	<b>C</b>		<b>1</b>	<b>G</b>	<b>0A</b>							

© Kayden Instruments All rights reserved. Contents subject to change without notice. Please refer to kayden.com for current specifications and configurations.

Model Number Legend  
DOC#: ML-812-004

ML-812-004-[011]

This is a Controlled Document and cannot be changed without the Approval of the Quality Control Manager.



<b>830</b>	<b>CODE</b>	<b>Sensor Type</b>													
	<b>R</b>	-45°C to +200°C (-50°F to +392°F) Continuous Service													
	<b>CODE</b>	<b>Sensor Material</b>													
	<b>A3</b>	316/316L Stainless Steel c/w Nickel Braze													
	<b>CODE</b>	<b>Process Connection - FNPT</b>													
	<b>D</b>	3/4"													
	<b>CODE</b>	<b>Sensor Assembly Body Length</b>													
	<b>0035</b>	3.5" (8.8 cm)													
	<b>CODE</b>	<b>Bleed Port</b>													
	<b>A</b>	Standard													
	<b>CODE</b>	<b>Sensor Mounting Orientation</b>													
	<b>H</b>	Horizontal Pipe													
	<b>V</b>	Vertical Pipe													
	<b>CODE</b>	<b>Injection Tubes (3/4" MNPT x 1/4" FNPT)</b>													
	<b>0</b>	Not Required													
	<b>1</b>	Type 1; .180" Bore; 316/316L Stainless Steel													
	<b>2</b>	Type 2; .086" Bore; 316/316L Stainless Steel													
	<b>CODE</b>	<b>Mounting Bracket Kit</b>													
	<b>A</b>	Not Required													
	<b>B</b>	90° Angle Bracket with hardware for wall/stand mounting													
	<b>CODE</b>	<b>Power</b>													
	<b>C</b>	12-24 VDC and 115-230 VAC, 50 to 60 Hz													
	<b>Electronics</b>														
	Microprocessor Controlled with User Interface. Two SPDT sealed relay contacts. Modbus via RS-485. 4-20 mA current loop.														
	<b>CODE</b>	<b>Local Enclosure</b>													
	<b>1</b>	Flameproof - Aluminum													
	<b>CODE</b>	<b>Cover - For Local Enclosure / Sensor Enclosure</b>													
	<b>B</b>	Blind Cover - Flameproof													
	<b>G</b>	Glass Lens Cover - Flameproof													
	<b>CODE</b>	<b>Remote Electronics Enclosure &amp; Cover</b>													
	<b>0A</b>	Not Required													
	<b>1B</b>	Blind Cover - Flameproof													
	<b>1G</b>	Glass Lens Cover - Flameproof													
	<b>CODE</b>	<b>Agency Approvals</b>													
	<b>1</b>	UL & CSA													
	<b>9</b>	FM													
	<b>CODE</b>	<b>Language</b>													
	<b>E</b>	English													
<b>830</b>	<b>R</b>	<b>A3</b>	<b>D</b>	<b>0035</b>	<b>A</b>	<b>H</b>	<b>1</b>	<b>A</b>	<b>C</b>	<b>1</b>	<b>B</b>	<b>0A</b>	<b>1</b>	<b>E</b>	



Flow, Level & Temperature Switch & Transmitter

© Kayden Instruments All rights reserved. Contents subject to change without notice. Please refer to kayden.com for current specifications and configurations.

Model Number Legend  
DOC#: ML-830-004

ML-830-004-[011]

This is a Controlled Document and cannot be changed without the Approval of the Quality Control Manager.

<b>832</b>		<b>CODE</b>	<b>Sensor Type</b>																
	<b>R</b>		-45°C to +200°C (-50°F to +392°F) Continuous Service																
		<b>CODE</b>	<b>Sensor Material</b>																
		<b>A3</b>	316/316L Stainless Steel c/w Nickel Braze																
		<b>CODE</b>	<b>Process Connection - Flange Type</b>																
		<b>A</b>	Raised Face																
		<b>B</b>	RTJ - Ring Type Joint																
 <p><b>Flow, Level &amp; Temperature Switch &amp; Transmitter</b></p>																			
<b>CODE</b>	<b>ANSI</b>	<b>CODE</b>	<b>ANSI</b>	<b>CODE</b>	<b>ANSI</b>	<b>CODE</b>	<b>ANSI</b>	<b>CODE</b>	<b>ANSI</b>	<b>CODE</b>	<b>ANSI</b>	<b>CODE</b>	<b>ANSI</b>	<b>CODE</b>	<b>ANSI</b>	<b>CODE</b>	<b>ANSI</b>	<b>CODE</b>	<b>ANSI</b>
	<b>3/4"</b>		<b>1"</b>		<b>1-1/2"</b>		<b>2"</b>		<b>3"</b>		<b>4"</b>		<b>5"</b>		<b>6"</b>		<b>8"</b>		<b>10"</b>
<b>111</b>	150	<b>121</b>	150	<b>131</b>	150	<b>141</b>	150	<b>151</b>	150	<b>161</b>	150	<b>171</b>	150	<b>181</b>	150	<b>191</b>	150	<b>201</b>	150
<b>112</b>	300	<b>122</b>	300	<b>132</b>	300	<b>142</b>	300	<b>152</b>	300	<b>162</b>	300	<b>172</b>	300	<b>182</b>	300	<b>192</b>	300	<b>202</b>	300
<b>113</b>	600	<b>123</b>	600	<b>133</b>	600	<b>143</b>	600	<b>153</b>	600	<b>163</b>	600	<b>173</b>	600	<b>183</b>	600	<b>193</b>	600	<b>203</b>	600
<b>114</b>	900	<b>124</b>	900	<b>134</b>	900	<b>144</b>	900	<b>154</b>	900	<b>164</b>	900	<b>174</b>	900	<b>184</b>	900	<b>194</b>	900	<b>204</b>	900
		<b>CODE</b>	<b>Flange Material</b>																
		<b>A</b>	316/316L Stainless Steel																
		<b>CODE</b>	<b>Sensor Assembly Body Length (Flange Face to Flange Face)</b>																
		<b>I0000</b>	Custom Body Lengths: Available in 1/2" (1.0 cm) increments. eg. 16.0" = 0160 ('M' = cm) 7" - 72" (relative to flange size/rating)																
		<b>CODE</b>	<b>Bleed Port</b>																
		<b>A</b>	1/4" Threaded - Standard																
		<b>CODE</b>	<b>Sensor Orientation</b>																
		<b>H</b>	Horizontal																
		<b>V</b>	Vertical																
		<b>CODE</b>	<b>Pipe Schedule</b>																
		<b>0</b>	Schedule 40																
		<b>1</b>	Schedule 80 (Standard)																
		<b>CODE</b>	<b>Input Power</b>																
		<b>C</b>	12-24 VDC and 115-230 VAC, 50 to 60 Hz																
		<b>Electronics</b>																	
		Microprocessor Controlled with User Interface. Two SPDT sealed relay contacts. Modbus via RS-485. 4-20 mA current loop.																	
		<b>CODE</b>	<b>Local Enclosure</b>																
		<b>1</b>	Flameproof - Aluminum																
		<b>CODE</b>	<b>Cover - For Local Enclosure / Sensor Enclosure</b>																
		<b>B</b>	Blind Cover - Flameproof																
		<b>G</b>	Glass Lens Cover - Flameproof																
		<b>CODE</b>	<b>Remote Electronics Enclosure &amp; Cover</b>																
		<b>0A</b>	Not Required																
		<b>1B</b>	Blind Cover - Flameproof																
		<b>1G</b>	Glass Lens Cover - Flameproof																
		<b>CODE</b>	<b>Agency Approvals</b>																
		<b>1</b>	UL & CSA																
		<b>9</b>	FM																
		<b>CODE</b>	<b>Language</b>																
		<b>E</b>	English																
<b>832</b>	<b>R</b>	<b>A3</b>	<b>A</b>	<b>131</b>	<b>A</b>	<b>I0060</b>	<b>A</b>	<b>H</b>	<b>0</b>	<b>C</b>		<b>1</b>	<b>G</b>	<b>0A</b>	<b>9</b>	<b>E</b>			

© Kayden Instruments All rights reserved. Contents subject to change without notice. Please refer to kayden.com for current specifications and configurations.

Model Number Legend  
DOC#: ML-832-004

ML-832-004-[011]

This is a Controlled Document and cannot be changed without the Approval of the Quality Control Manager.

# KAYDEN | CLASSIC™ 816 Threaded Retractable Packing Gland

<b>816</b>	<b>CODE</b>	<b>Sensor Type</b>										
	<b>R</b>	-45°C to +160°C (-50°F to +320°F) Continuous Service										
		<b>CODE</b> <b>Sensor Material</b>										
		<b>A</b>	316/316L Stainless Steel									
		<b>X</b>	Titanium Gr. 2									
		<b>T</b>	Hastelloy C-276									
		<b>CODE</b> <b>Process Connection - MNPT</b>										
		<b>E</b>	1"									
		<b>CODE</b> <b>Insertion 'U' Lengths</b>										
		<b>T</b>	Low Pressure; 316/316L Stainless Steel (MWP 50 psi)									
		<b>J</b>	Low Pressure c/w Retaining Chain; 316/316L Stainless Steel (MWP 125 psi)									
		<b>X</b>	Medium Pressure; 316/316L Stainless Steel (MWP 500 psi)									
		<b>CODE</b> <b>Insertion 'U' Lengths</b>										
		<b>0060</b>	6"	(15.2 cm)								
		<b>0120</b>	12"	(30 cm)								
		<b>0180</b>	18"	(46 cm)							Custom 'U' Lengths:	
		<b>0240</b>	24"	(60 cm)							2.5" - 120" (6.0 cm - 305 cm)	
		<b>0360</b>	36"	(91 cm)							Available in 1/2" (1.0 cm) increments.	
		<b>0480</b>	48"	(121 cm)								
		<b>0600</b>	60"	(152 cm)								
		<b>IXXXX</b>	Custom 'U' Lengths: Use 4 digits preceded by an 'I' (i.e. 3.5" 'U' = I0035) (Use 'M' for cm)									
		<b>CODE</b> <b>Input Power</b>										
		<b>C</b>	12-24 VDC and 115-230 VAC, 50 to 60 Hz									
		<b>Electronics</b>										
		Microprocessor Controlled with User Interface.										
		Two SPDT sealed relay contacts. Modbus via RS-485. 4-20 mA current loop.										
		<b>CODE</b> <b>Local Enclosure</b>										
		<b>1</b>	Flameproof - Aluminum									
		<b>CODE</b> <b>Cover - For Local Enclosure</b>										
		<b>B</b>	Blind Cover - Flameproof									
		<b>G</b>	Glass Lens Cover - Flameproof									
		<b>CODE</b> <b>Remote Electronics Enclosure &amp; Cover</b>										
		<b>0A</b>	Not Required									
		<b>1B</b>	Blind Cover - Flameproof									
		<b>1G</b>	Glass Lens Cover - Flameproof									
		<b>CODE</b> <b>Agency Approvals</b>										
		<b>1</b>	UL & CSA									
		<b>9</b>	FM									
		<b>CODE</b> <b>Language</b>										
		<b>E</b>	English									
<b>816</b>	<b>R</b>	<b>A</b>	<b>E</b>	<b>T</b>	<b>0020</b>	<b>C</b>		<b>1</b>	<b>G</b>	<b>0A</b>	<b>9</b>	<b>E</b>

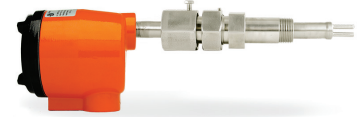

Flow, Level, Interface & Temperature Switch & Transmitter

© Kayden Instruments All rights reserved. Contents subject to change without notice.  
Please refer to kayden.com for current specifications and configurations.

Model Number Legend  
DOC#: ML-816-004

ML-816-004-[011]  
This is a Controlled Document and cannot be changed without the Approval of the Quality Control Manager.

**\*Sensor only.** The Packing Gland Assembly is available as standard in 316/316L Stainless Steel. For exotic alloys contact Kayden.

# KAYDEN | CLASSIC™ 814 Flanged Retractable Packing Gland

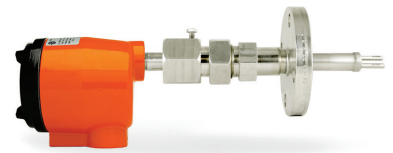

Flow, Level, Interface & Temperature Switch & Transmitter

<b>814</b>	<b>CODE</b>	<b>Sensor Type</b>															
	<b>R</b>	-45°C to +160°C (-50°F to +320°F) Continuous Service															
	<b>CODE</b>	<b>Sensor Material</b>															
	<b>A</b>	316/316L Stainless Steel															
	<b>X</b>	Titanium Gr. 2															
	<b>T</b>	Hastelloy C-276															
	<b>CODE</b>	<b>Process Connection - Flange Type</b>															
	<b>A</b>	Raised Face															
	<b>B</b>	RTJ - Ring Type Joint															
	<b>CODE</b>	<b>ANSI</b>	<b>CODE</b>	<b>ANSI</b>	<b>CODE</b>	<b>ANSI</b>	<b>CODE</b>	<b>ANSI</b>	<b>CODE</b>	<b>ANSI</b>	<b>CODE</b>	<b>ANSI</b>	<b>CODE</b>	<b>ANSI</b>	<b>CODE</b>	<b>ANSI</b>	
		<b>1-1/2"</b>		<b>2"</b>		<b>3"</b>		<b>4"</b>		<b>5"</b>		<b>6"</b>		<b>8"</b>		<b>10"</b>	
		<b>131</b>	<b>150</b>	<b>141</b>	<b>150</b>	<b>151</b>	<b>150</b>	<b>161</b>	<b>150</b>	<b>171</b>	<b>150</b>	<b>181</b>	<b>150</b>	<b>191</b>	<b>150</b>	<b>201</b>	<b>150</b>
	<b>CODE</b>	<b>Flange Material</b>															
	<b>A</b>	316/316L SST	<b>X</b>	Titanium Gr. 2													
	<b>T</b>	Hastelloy C-276															
	<b>CODE</b>	<b>Retraction Assembly</b>															
	<b>T</b>	Low Pressure; 316/316L Stainless Steel (MWP 50 psi)															
	<b>J</b>	Low Pressure c/w Retaining Chain; 316/316L Stainless Steel (MWP 125 psi)															
	<b>X</b>	Medium Pressure; 316/316L Stainless Steel (MWP 275 psi)															
	<b>CODE</b>	<b>Insertion 'U' Lengths</b>	2.5" - 120" (6.4 cm - 305 cm) in 1/2" (1.0 cm) increments.														
	<b>IXXXX</b>	Custom 'U' Lengths: Use 4 digits preceded by an 'I' (i.e. 3.5" 'U' = I0035)	('M' = cm)														
	<b>CODE</b>	<b>Input Power</b>															
	<b>C</b>	12-24 VDC and 115-230 VAC, 50 to 60 Hz															
		<b>Electronics</b>	Microprocessor Controlled with User Interface. Two SPDT sealed relay contacts. Modbus via RS-485. 4-20 mA current loop.														
	<b>CODE</b>	<b>Local Enclosure</b>															
	<b>1</b>	Flameproof - Aluminum															
	<b>CODE</b>	<b>Cover - For Local Enclosure / Sensor Enclosure</b>															
	<b>B</b>	Blind Cover - Flameproof															
	<b>G</b>	Glass Lens Cover - Flameproof															
	<b>CODE</b>	<b>Remote Electronics Enclosure &amp; Cover</b>															
	<b>0A</b>	Not Required															
	<b>1B</b>	Blind Cover - Flameproof															
	<b>1G</b>	Glass Lens Cover - Flameproof															
	<b>CODE</b>	<b>Agency Approvals</b>															
	<b>1</b>	UL & CSA															
	<b>9</b>	FM															
	<b>CODE</b>	<b>Language</b>															
	<b>E</b>	English															
<b>814</b>	<b>R</b>	<b>A</b>	<b>A</b>	<b>131</b>	<b>A</b>	<b>T</b>	<b>I0035</b>	<b>C</b>		<b>1</b>	<b>G</b>	<b>0A</b>	<b>9</b>	<b>E</b>			

© Kayden Instruments All rights reserved. Contents subject to change without notice. Please refer to kayden.com for current specifications and configurations.

Model Number Legend  
DOC#: ML-814-004

ML-814-004-[011]

This is a Controlled Document and cannot be changed without the Approval of the Quality Control Manager.

**\*Sensor only.** The Packing Gland Assembly is available as standard in 316/316L Stainless Steel. For exotic alloys contact Kayden.

<b>828</b>	<b>CODE</b>	<b>Sensor Type</b>									
	<b>R</b>	-45°C to +200°C (-50°F to +392°F) Continuous Service									
	<b>CODE</b>	<b>Sensor Material</b>									
	<b>A6</b>	316/316L Stainless Steel									
	<b>CODE</b>	<b>Process Connection - Tri-Clamp</b>									
	<b>E</b>	1"									
	<b>G</b>	1.5"									
	<b>H</b>	2"									
	<b>J</b>	2.5"									
	<b>K</b>	3"									
	<b>L</b>	3.5"									
	<b>CODE</b>	<b>Insertion 'U' Lengths</b>									
	<b>0020</b>	2" (5.0 cm)	Custom 'U' Lengths: 2.5" - 120" (6.0 cm - 305 cm) Available in 1/2" (1.0 cm) increments.								
	<b>0030</b>	3" (7.5 cm)									
	<b>0040</b>	4" (10.1 cm)									
	<b>0060</b>	5" (15.2 cm)									
	<b>IXXXX</b>	Custom 'U' Lengths: Use 4 digits preceded by an 'I' (i.e. 3.5" 'U' = I0035) (Use 'M' for cm)									
	<b>CODE</b>	<b>Input Power</b>									
	<b>1</b>	12-24 VDC and 115-230 VAC, 50 to 60 Hz									
		<b>Electronics</b>									
		Microprocessor Controlled with User Interface.									
		Two SPDT sealed relay contacts. Modbus via RS-485. 4-20 mA current loop.									
	<b>CODE</b>	<b>Local Enclosure</b>									
	<b>1</b>	Flameproof - Aluminum									
	<b>CODE</b>	<b>Cover - For Local Enclosure</b>									
	<b>B</b>	Blind Cover - Flameproof									
	<b>G</b>	Glass Lens Cover - Flameproof									
	<b>CODE</b>	<b>Remote Electronics Enclosure &amp; Cover</b>									
	<b>0A</b>	Not Required									
	<b>1B</b>	Blind Cover - Flameproof									
	<b>1G</b>	Glass Lens Cover - Flameproof									
	<b>CODE</b>	<b>Agency Approvals</b>									
	<b>1</b>	UL & CSA									
	<b>9</b>	FM									
	<b>CODE</b>	<b>Language</b>									
	<b>E</b>	English									
<b>828</b>	<b>R</b>	<b>A6</b>	<b>E</b>	<b>0020</b>	<b>C</b>	<b>1</b>	<b>G</b>	<b>0A</b>	<b>9</b>	<b>E</b>	

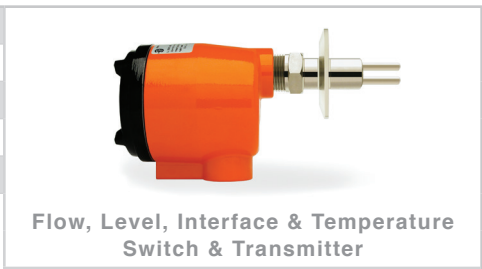

© Kayden Instruments. All rights reserved. Contents subject to change without notice. Please refer to kayden.com for current specifications and configurations.

Model Number Legend  
DOC#: ML-828-004

ML-828-004-[011]

This is a Controlled Document and cannot be changed without the Approval of the Quality Control Manager.

## C

**kayden.com Web Site**

**kayden.com** is a comprehensive resource for most customer requirements.

The site offers a means to:

- **Configure Products**, Spare Parts and Accessories
- **Compare our products** to determine those best suited to your application
- View and print **Product Manuals**
- View and print **Outline Dimensional Drawings, Wiring Diagrams & Parts Lists**
- View and print **Quick Setup Guides**
- View and print **Product Specifications and Brochures**
- View our **Support Section for Troubleshooting Assistance**
- View our Corporate Policies (satisfaction guarantee, returns, repairs, etc.)
- View a brief list of **Kayden Customers**
- Download **Kayden RCM Software**
- View and print **Approval Certificates**









# KAYDEN®

This document and other information from Kayden and its authorized distributors, provides product and/or system options for further investigation by users having technical expertise. It is important that you analyze all aspects of your application and review the information concerning the product or system in the current catalog located online at [kayden.com](http://kayden.com).

Copyright 1994 – 2017 Telematic Controls Inc. (the Kayden Instruments line of products is manufactured by Telematic Controls Inc.). All rights reserved.

® <sup>TM</sup>, **KAYDEN, CLASSIC, RCM, RCMS, Remote Control & Monitoring Software, SCA, and Helping the World Switch** are trademarks, the property of Telematic Controls Inc.

Tri-Clamp® is a registered trademark of Alfa Laval Inc.

Estane® is a registered trademark of Lubrizol Corporation

Hastelloy® is a registered trademark of Haynes International, Inc.

Inconel®, Incoloy® Alloy 20, Monel® are registered trademarks of Special Metals Corporation

Kayden products are protected by Canadian and International patents.

This catalog is for informational purposes only.

The information contained herein is believed to be reliable, but no representations, guarantees or warranties of any kind are made as to its accuracy, suitability for particular applications or the results to be obtained therefrom. The information is based on laboratory work with small-scale equipment and does not necessarily indicate end product performance. Because of the variations in methods, conditions and equipment used commercially in applying these products, no warranties or guarantees are made as to the suitability of the products for the application(s) disclosed. Full-scale testing and end product performance are the responsibility of the user. Kayden Instruments shall not be liable for and the customer assumes all risk and liability of any use of handling of any product beyond Kayden Instruments direct control.

THE SELLER MAKES NO WARRANTIES, EXPRESS OR IMPLIED, INCLUDING, BUT NOT LIMITED TO, THE IMPLIED WARRANTIES OF MERCHANTABILITY AND FITNESS FOR A PARTICULAR PURPOSE. Nothing contained herein is to be considered as permission, recommendation, nor as an inducement to practice any patented invention without permission of the patent owner.

## Ordering Information

### Order Online

kayden.com Utilize our eCommerce website to order your Kayden products from your Authorized Kayden Distributor, or directly from Kayden. Please know that your local Authorized Distributor is supported whether you place orders online, via telephone, or email.

## Contact Us

### Telephone

1 (403) 253-1423  
001 403 253-1423

### Fax

1 (403) 255-0042 North America  
001 403 255-0042 International

### E-Mail

info@kayden.com

### Web

kayden.com

**Hours** Monday – Friday 8:00 a.m. – 5:00 p.m. MST

**Mailing Address** 3364–114th Avenue S.E., Calgary, Alberta, Canada T2Z 3V6

## Contact a Local Distributor

### Distributors

Visit kayden.com to find a local Distributor near you. Distributors provide local inventory, technical support and service.

## 60-Day 100% Satisfaction Guarantee

### Standard Products

Standard Products are eligible for the 60-Day 100% Satisfaction Guarantee. If you purchased new Standard Products, you may return them to the place of purchase up to 60 days from the date of invoice for a refund or credit of the product purchase price provided the quantity of Products does not exceed twenty-five units (nominal restocking fee apply to only those quantities exceeding twenty-five units).

### Custom Products

Custom Products are not eligible for this guarantee as they are manufactured specifically to the customers' individual and unique requirements. Ship returns prepaid. Please note the refund or credit will not include any charges for special documentation, special equipment, special service, special approvals, drawings, certificates, equipment tags, set points, flow curves, x-rays, dye penetration tests, opened software, shipping or insurance shown on your invoice. View the Return Policy in detail at kayden.com.

Kayden offers the following:

- 60 calendar days from the date of invoice.
- Up to twenty-five (25) Standard Products of any type or combination per order. Should the customer, for any reason, be unsatisfied with any or all of the Products, he/she may return any or all of them for a full refund.

Visit kayden.com to view the 60-Day 100% Satisfaction Guarantee in detail.

## Warranty

One (1) Year from shipment date from factory (see Terms & Conditions of Sale).

# **KAYDEN<sup>®</sup>**

## **Helping the World Switch<sup>™</sup>**



For more information about the CLASSIC Series or any of Kayden's other products, please visit [kayden.com](http://kayden.com)