



Retrofitting sewage plants with lightning and surge protection measures

White Paper



Contents

- Assessment of the risk for the operations building
- Plant description
- Lightning protection zone concept
- Lightning protection system
- Lightning equipotential bonding for all conductive systems entering the sewage plant
- Equipotential bonding
- Surge protection for the low-voltage power supply system
- Surge protection for information technology systems

Retrofitting sewage plants with lightning and surge protection measures

White Paper



A more efficient use of drinking water is growing in significance, especially against a backdrop of increasingly scarce drinking water resources. Therefore, sewage plants are a key element of the drinking water cycle. The necessary high efficiency of sewage plants (**Figure 1**) requires that the operating procedure be optimised and the operating costs be reduced at the same time. For this purpose, high investments were made in electronic measuring equipment and distributed electronic control and automation systems over the last years. However, these new electronic systems only provide a low resistance to transients compared to conventional technology. The structural conditions of the widespread outdoor wastewater treatment systems with measuring equipment and control units extending over large areas additionally increase the risk of interference caused by lightning discharges or surges. Thus, it is most likely that the complete process control system or parts thereof fail if no protection measures are taken. The consequences of such a failure can be serious ranging from costs for re-establishing the availability of the sewage plant to the unknown costs for eliminating ground water contamination. Consequently, external and internal lightning protection measures must be taken to efficiently eliminate this threat and to increase the availability of the systems.

Assessment of the risk for the operations building

The example described in the following was calculated based on the IEC 62305-2 (EN 62305-2) standard. We expressly point out that the procedure shown is only an example. This

solution is not binding in any way and can be substituted by other equivalent solutions. In the following, only the essential characteristics of the example will be shown. At first, a questionnaire with important questions on the structure and its use was discussed and filled in together with the operator. This procedure allows to prepare a lightning protection concept that is comprehensible for all parties involved. The concept includes the minimum requirements which, however, can be technically improved at any time.

Plant description

The complete process control system of the sewage plant is centrally located in the operations building. In case of a lightning strike, substantial partial lightning currents and surges are injected into the switch rooms via the extended cables leading to measuring stations and substations. In the past, this caused destruction and failure of the plant over and over again. The same applies to the power supply and telephone line. The operations building itself must be protected against damage resulting from fire (caused by a direct lightning strike) and the electrical and electronic systems (control and automation system, telecontrol system) from the effects of the lightning electromagnetic pulse (LEMP).

Additional conditions:

- ➔ Protection measures against lightning effects have already been taken (external lightning protection system accord-

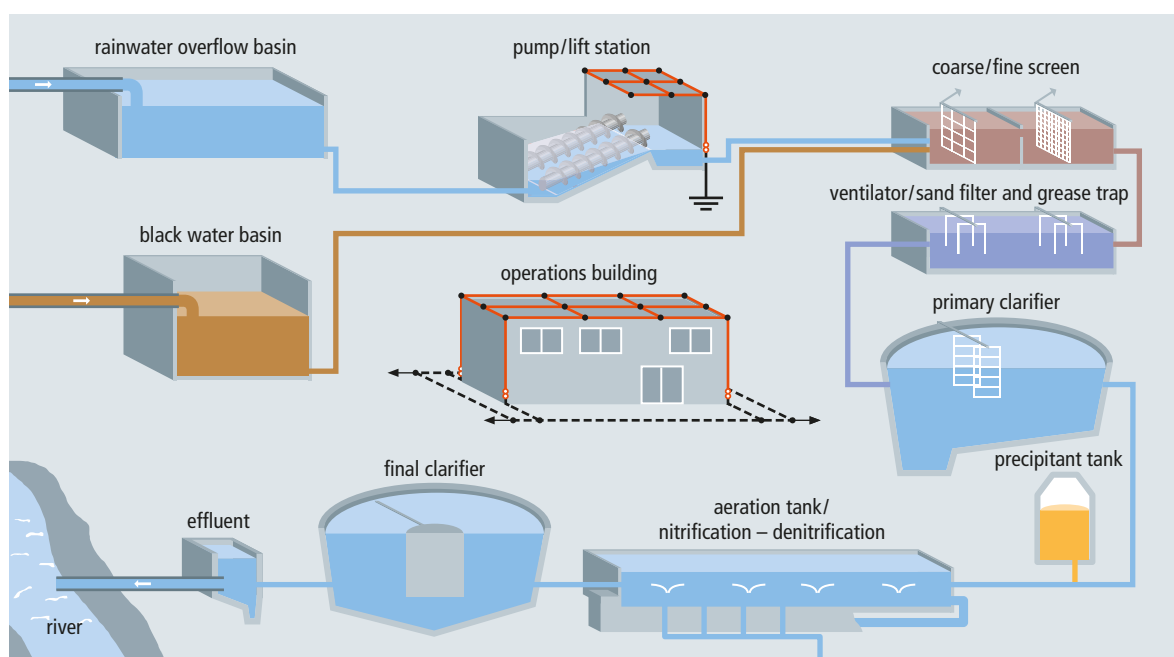

Figure 1 Schematic diagram of a sewage plant

Retrofitting sewage plants with lightning and surge protection measures

White Paper



ing to the previous IEC 62305-1 (EN 62305-1) standard, VGA 280/4 surge protective devices (SPDs) installed at the entrance point of the 230/400 V power supply line into the building, VM 280 SPDs of requirement class C installed in the switchgear cabinets of the measuring and control equipment).

- ➔ The following types of loss are relevant: L2: Loss of service to the public (water supply and wastewater disposal) and L4: Loss of economic value (structures and their contents). Type of damage L1: Loss of human life was excluded since the plant will be fully automated at a later date.

An assessment of the actual state shows that the calculated risk R for the types of damage L2 and L4 is still considerably higher than the tolerable risk R_T .

Possible protection measures are taken to ensure $R < R_T$ for both types of damage:

- ➔ Installation of a lightning protection system with class of LPS III according to IEC 62305-3 (EN 62305-3) (this com-

plies with the recommendations in the German VdS publication 2010).

- ➔ Installation of type 1 SPDs according to IEC 61643-11 (EN 61643-11) (power supply) and SPDs of category D1 according to IEC 61643-21 (EN 61643-21) for the information technology lines (measuring and control lines as well as telecommunication lines) at the zone transitions from LPZ 0_A to 1.
- ➔ Type 2 SPDs according to IEC 61643-11 (EN 61643-11) (power supply) and surge protective devices of category C2 according to IEC 61643-21 (EN 61643-21) for the information technology lines (measuring and control lines as well as telecommunication lines) at the zone transitions from LPZ 0_B to 1 and 1 to 2.

Lightning protection zone concept

To ensure maximum technical and economic protection, the operations building is subdivided into lightning protection zones (LPZs). Subsequently, a risk analysis is carried out for each LPZ and the relevant types of damage. The mutual dependences of the LPZs are then examined and the required

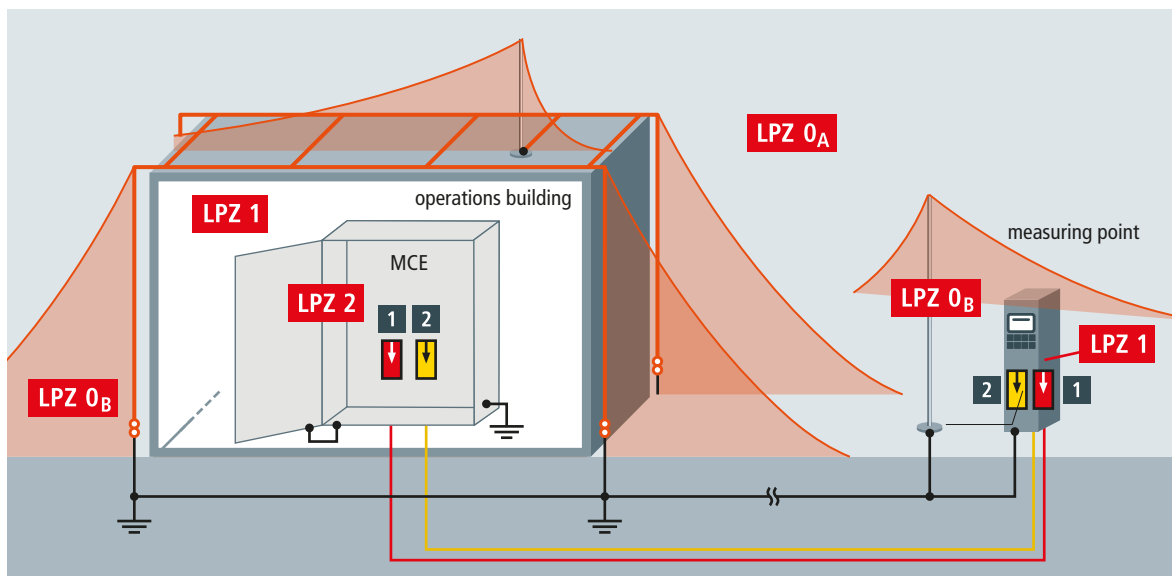

	Protection for...	Type	Part No.
1	Power supply system	TN system	DEHNguard DG M TN 275 952 200 DEHNguard DG M TN 275 FM 952 205
		TT system	DEHNguard DG M TT 2P 275 or 952 110 DEHNguard DG M TT 2P 275 FM 952 115
2	Oxygen measurement device	e.g. 4 to 20 mA	BLITZDUCTOR BXT ML4 BE S 24 + BXT BAS base part or 920 224 + 920 300 BLITZDUCTOR BXT ML2 BE 24 + BXT BAS base part 920 324 + 920 300

Figure 2 Division of the operations building into lightning protection zones; example: selection of surge protective devices for the oxygen measurement device

Retrofitting sewage plants with lightning and surge protection measures

White Paper

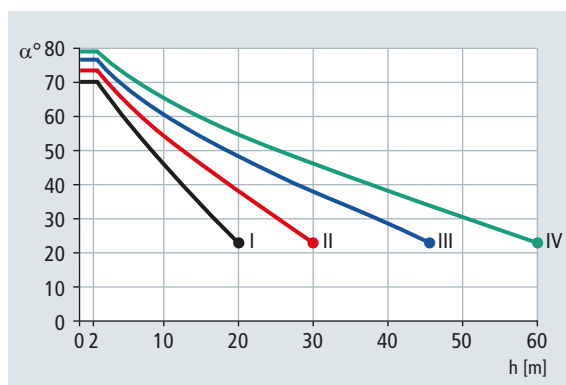

Figure 3 Protective angle method according to IEC 62305-3 (EN 62305-3)

protection measures are defined to reach the necessary protection goal in all lightning protection zones. The following areas were subdivided into lightning protection zone 1 (LPZ 1) and lightning protection zone 2 (LPZ 2):

- ➔ Evaluation unit in the control room (LPZ 2)
- ➔ Oxygen measurement device in the aeration tank (LPZ 1)
- ➔ Interior of the control room (LPZ 1)

According to the lightning protection zone concept described in IEC 62305-4 (EN 62305-4), all lines at the boundaries of lightning protection zones must be protected by suitable surge protection measures.

Figure 2 exemplarily shows suitable surge protection measures for the oxygen measurement device in the aeration tank. The field cables are located in LPZ 0_B throughout their entire course. Therefore, type 2 SPDs can be used for protecting the oxygen measurement device and the control systems since (partial) lightning currents are not to be expected in LPZ 0_B.

Lightning protection system

The existing lightning protection system of the operations building was tested according to the requirements of class of LPS III. The indirect connection of the roof-mounted structures (air-conditioning systems) via isolating spark gaps was removed. Air-termination rods with the required separation distances and protective angles were used to protect the sewage plant from a direct lightning strike (**Figure 3**). Consequently, in case of a direct lightning strike to the control room, partial lightning currents can no longer flow into the structure and cause damage. Due to the dimensions of the control room (15 m x 12 m), the number of down conductors (4) did not have to be changed. The local earth-termination system of the operations building was tested at all measuring points and the values were documented. Retrofitting was not required.

Lightning equipotential bonding for all conductive systems entering the sewage plant

In principle, all conductive systems entering the sewage plant must be integrated in the lightning equipotential bonding (**Figure 4**). This is achieved by directly connecting all metal systems and indirectly connecting all live systems via surge protective devices. Type 1 SPDs (power supply systems) and category D1 SPDs (information technology systems) must have a discharge capacity of 10/350 μ s test waveform. Lightning equipotential bonding should be established as close as possible to the entrance point into the structure to prevent lightning currents from entering the building.

Equipotential bonding

Consistent equipotential bonding according to IEC 60364-4-41 (HD 60364-4-41), IEC 60364-5-54 (HD 60364-5-54) and IEC 62305-3 (EN 62305-3) is established in the entire operations building. The existing equipotential bonding system is tested to avoid potential differences between different extraneous conductive parts. Supporting and structural parts of the building, pipes, containers, etc. are integrated in the equipotential bonding system so that voltage differences do not have to be expected, even in case of failure. If surge protective devices are used, the cross-section of the copper earthing conductor for equipotential bonding must be at least 16 mm² in case of SPDs for power supply systems and at least 6 mm² in case of SPDs for information technology systems (e.g. BLITZDUCTOR) or the cross section specified in the installation instructions must be used. Moreover, in areas with potentially explosive atmospheres the connections of the equipotential bonding conductors e.g. at equipotential bonding bars must be secured against self-loosening (e.g. by means of spring washers).

Surge protection for the low-voltage power supply system

In the described application, the VGA 280/4 surge protective device installed at the entrance point into the building is replaced by a DEHNventil M TNS 255 FM type 1 combined arrester (**Figure 5**) since the "old" SPD no longer fulfils the requirements for lightning protection systems according to IEC 62305-3 (EN 62305-3). The VM 280 type 2 SPDs were tested by means of a PM 10 arrester test unit. Since the test values were still within the tolerances, the SPDs did not have to be removed. If further SPDs are installed for protecting terminal equipment, they must be coordinated with each other and with the terminal equipment to be protected. The relevant installation instructions must be observed.

In other respects, the use of surge protective devices in the low-voltage consumer's installation does not differ from other

Retrofitting sewage plants with lightning and surge protection measures

White Paper

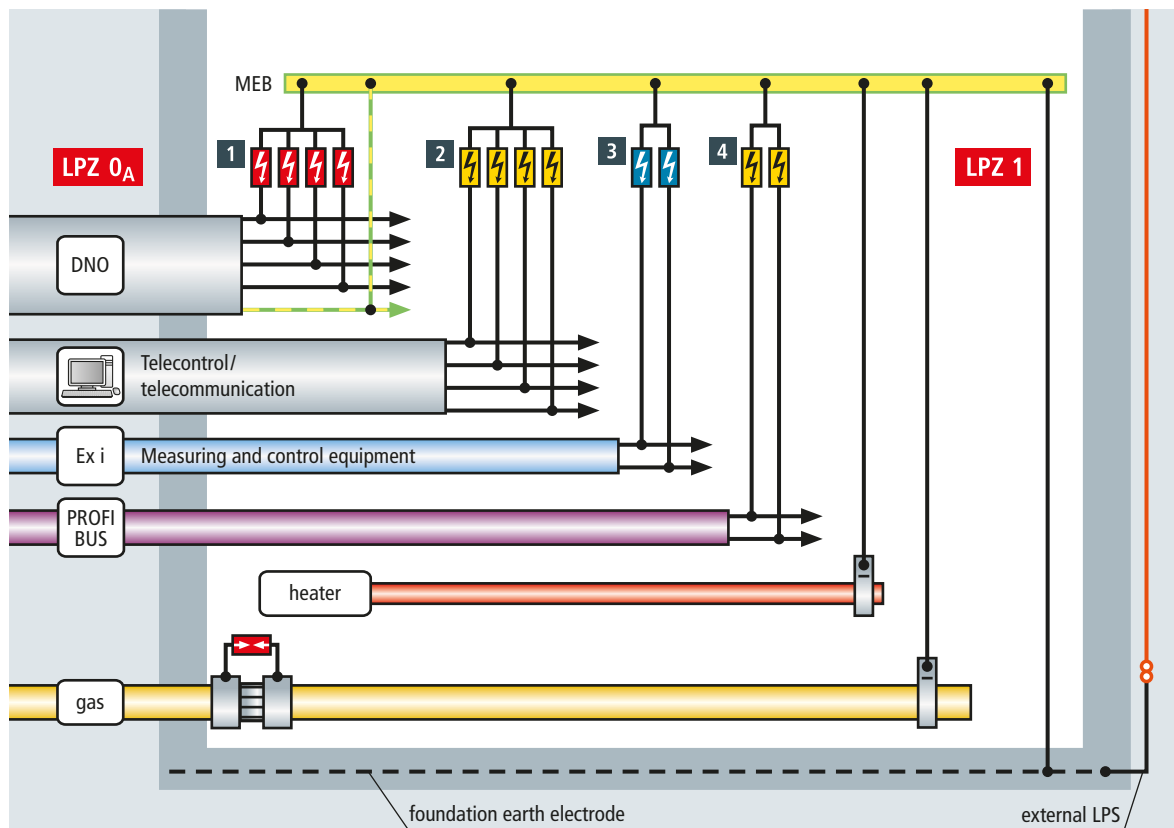

No. in Fig.	Protection for	Surge protective device	*floating remote signalling contact	Part No.
Power supply systems				
1	TN-C system	DEHNventil DV M TNC 255		951 300
		DEHNventil DV M TNC 255 FM*		951 305
	TN-S/TT system	DEHNventil DV M TT 255		951 310
		DEHNventil DV M TT 255 FM*		951 315
Information technology systems				
2	Telecontrol, telecommunication	BLITZDUCTOR BXT ML2 BD 180 or BLITZDUCTOR BXT ML4 BD 180 + BXT BAS base part		920 247 920 347 + 920 300
Measuring and control equipment				
3	Intrinsically safe measuring circuits + systems	BLITZDUCTOR BXT ML2 BD S EX 24 or BLITZDUCTOR BXT ML4 BD EX 24 + BXT BAS base part		920 280 920 381 + 920 301
Bus systems				
4	e.g. Profibus DP	BLITZDUCTOR BXT ML2 BD HFS 5 + BXT BAS base part		920 271 + 920 300

Figure 4 Lightning equipotential bonding according to DIN EN 62305-3 (VDE 0185-305-3), Supplement 1

Retrofitting sewage plants with lightning and surge protection measures

White Paper

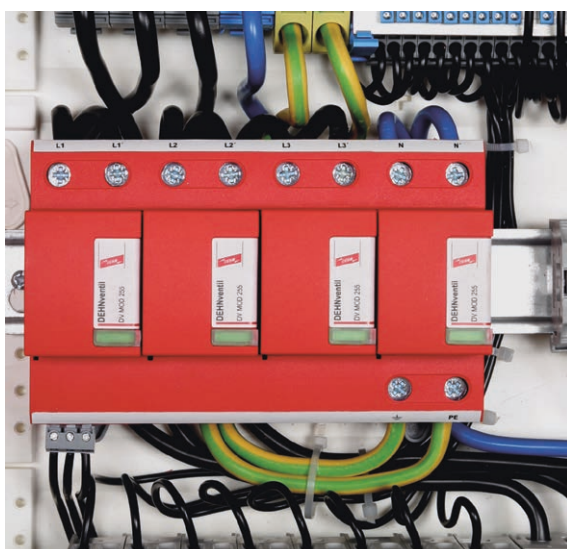

Figure 5 DEHNventil installed in a switchgear cabinet for protecting the power supply systems

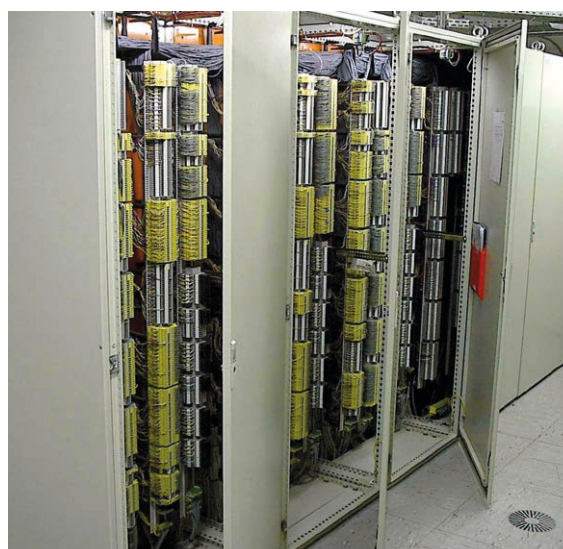

Figure 6 DEHNconnect terminal blocks with integrated surge protection for protecting the complete measuring and control equipment

applications (for more detailed information, please also see brochure DS 649 E "Red/Line Selection Guide").

Surge protection for information technology systems

The entrance point into the building serves as a transfer point between all information technology lines and the sewage plant. At this point, lightning current carrying SPDs (category D1), e.g. of type DRL 10 B 180 FSD, are installed. The lines are directly routed from this transfer point to the switchgear cabinets and are connected there. According to the risk analysis, the incoming lines for the 20 mA signals and the telecontrol system must be protected by adequate arresters from the DEHNconnect or BLITZDUCTOR series. These SPDs can be installed in conformity with the lightning protection zone concept (category C2) and are compatible with the system (Figures 6 and 7).

This ensures a consistent surge protection concept for the information technology lines.

Additional applications for protecting sewage plants can be found in brochure DS 107 E which can be downloaded at www.dehn-international.com.

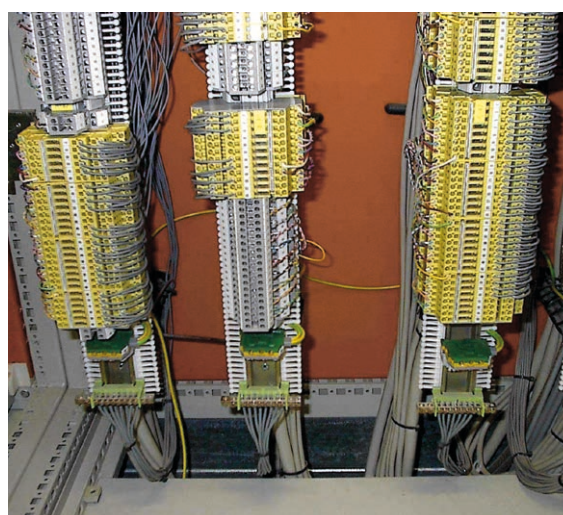

Figure 7 DEHNconnect surge protection devices; lines entering from the double floor

DEHNventil

DV M TNC 255 (951 300)

- Prewired combined type 1 and type 2 spark-gap-based lightning current and surge arrester consisting of a base part and plug-in protection modules
- Maximum system availability due to RADAX Flow follow current limitation
- Capable of protecting terminal equipment



Figure without obligation

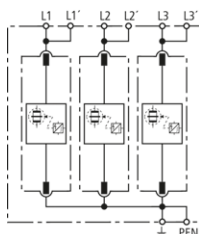

Basic circuit diagram DV M TNC 255

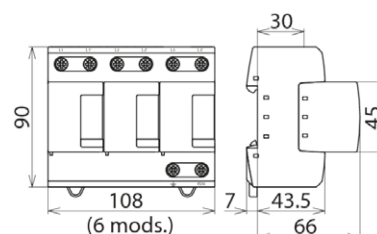

Dimension drawing DV M TNC 255

Modular combined lightning current and surge arrester for protecting TN-C systems against surges.

Type Part No.	DV M TNC 255 951 300
SPD according to EN 61643-11 / IEC 61643-11	type 1 + type 2 / class I + class II
Energy coordination with terminal equipment (≤ 5 m)	type 1 + type 2 + type 3
Nominal a.c. voltage (U_N)	230 / 400 V (50 / 60 Hz)
Max. continuous operating a.c. voltage (U_c)	264 V (50 / 60 Hz)
Lightning impulse current (10/350 μ s) [L1+L2+L3-PEN] (I_{total})	75 kA
Specific energy [L1+L2+L3-PEN] (W/R)	1.40 MJ/ohms
Lightning impulse current (10/350 μ s) [L-PEN] (I_{imp})	25 kA
Specific energy [L-PEN] (W/R)	156.25 kJ/ohms
Nominal discharge current (8/20 μ s) [L-PEN]/[L1+L2+L3-PEN] (I_n)	25 / 75 kA
Voltage protection level (U_p)	≤ 1.5 kV
Follow current extinguishing capability a.c. (I_n)	50 kA _{rms}
Follow current limitation / Selectivity	no tripping of a 20 A gL/gG fuse up to 50 kA _{rms} (prosp.)
Response time (t_A)	≤ 100 ns
Max. backup fuse (L) up to $I_K = 50$ kA _{rms}	315 A gG
Max. backup fuse (L-L')	125 A gG
Temporary overvoltage (TOV) (U_T) – Characteristic	440 V / 120 min. – withstand
Operating temperature range [parallel] / [series] (T_U)	-40 °C ... +80 °C / -40 °C ... +60 °C
Operating state / fault indication	green / red
Number of ports	1
Cross-sectional area (L1, L1', L2, L2', L3, L3', PEN, \pm) (min.)	10 mm ² solid / flexible
Cross-sectional area (L1, L2, L3, PEN) (max.)	50 mm ² stranded / 35 mm ² flexible
Cross-sectional area (L1', L2', L3', \pm) (max.)	35 mm ² stranded / 25 mm ² flexible
For mounting on	35 mm DIN rails acc. to EN 60715
Enclosure material	thermoplastic, red, UL 94 V-0
Place of installation	indoor installation
Degree of protection	IP 20
Capacity	6 module(s), DIN 43880
Approvals	KEMA, VDE, UL, VdS
Extended technical data:	Use in switchgear installations with prospective short-circuit currents of more than 50 kA _{rms} (tested by the German VDE)
– Max. prospective short-circuit current	100 kA _{rms} (220 kA _{peak})
– Limitation / Extinction of mains follow currents	up to 100 kA _{rms} (220 kA _{peak})
– Max. backup fuse (L) up to $I_K = 100$ kA _{rms}	315 A gL/gG
Weight	970 g
Customs tariff number	85363030
GTIN	4013364108134
PU	1 pc(s)

DEHNventil

DV M TNC 255 FM (951 305)

- Prewired combined type 1 and type 2 spark-gap-based lightning current and surge arrester consisting of a base part and plug-in protection modules
- Maximum system availability due to RADAX Flow follow current limitation
- Capable of protecting terminal equipment



Figure without obligation

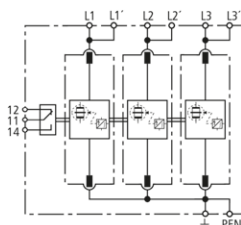

Basic circuit diagram DV M TNC 255 FM

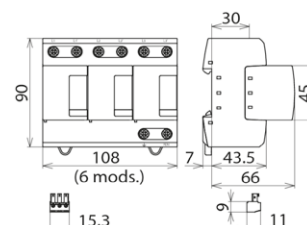

Dimension drawing DV M TNC 255 FM

Modular combined lightning current and surge arrester for TN-C systems.

Type	DV M TNC 255 FM
Part No.	951 305
SPD according to EN 61643-11 / IEC 61643-11	type 1 + type 2 / class I + class II
Energy coordination with terminal equipment (≤ 5 m)	type 1 + type 2 + type 3
Nominal a.c. voltage (U_N)	230 / 400 V (50 / 60 Hz)
Max. continuous operating a.c. voltage (U_C)	264 V (50 / 60 Hz)
Lightning impulse current (10/350 μ s) [L1+L2+L3-PEN] (I_{total})	75 kA
Specific energy [L1+L2+L3-PEN] (W/R)	1.40 MJ/ohms
Lightning impulse current (10/350 μ s) [L-PEN] (I_{imp})	25 kA
Specific energy [L-PEN] (W/R)	156.25 kJ/ohms
Nominal discharge current (8/20 μ s) [L-PEN]/[L1+L2+L3-PEN] (I_n)	25 / 75 kA
Voltage protection level (U_P)	≤ 1.5 kV
Follow current extinguishing capability a.c. (I_n)	50 kA _{rms}
Follow current limitation / Selectivity	no tripping of a 20 A gL/gG fuse up to 50 kA _{rms} (prosp.)
Response time (t_A)	≤ 100 ns
Max. backup fuse (L) up to $I_k = 50$ kA _{rms}	315 A gG
Max. backup fuse (L-L')	125 A gG
Temporary overvoltage (TOV) (U_T) – Characteristic	440 V / 120 min. – withstand
Operating temperature range [parallel] / [series] (T_U)	-40 °C ... +80 °C / -40 °C ... +60 °C
Operating state / fault indication	green / red
Number of ports	1
Cross-sectional area (L1, L1', L2, L2', L3, L3', PEN, \pm) (min.)	10 mm ² solid / flexible
Cross-sectional area (L1, L2, L3, PEN) (max.)	50 mm ² stranded / 35 mm ² flexible
Cross-sectional area (L1', L2', L3', \pm) (max.)	35 mm ² stranded / 25 mm ² flexible
For mounting on	35 mm DIN rails acc. to EN 60715
Enclosure material	thermoplastic, red, UL 94 V-0
Place of installation	indoor installation
Degree of protection	IP 20
Capacity	6 module(s), DIN 43880
Approvals	KEMA, VDE, UL, VdS
Type of remote signalling contact	changeover contact
a.c. switching capacity	250 V / 0.5 A
d.c. switching capacity	250 V / 0.1 A; 125 V / 0.2 A; 75 V / 0.5 A
Cross-sectional area for remote signalling terminals	max. 1.5 mm ² solid / flexible
Extended technical data:	Use in switchgear installations with prospective short-circuit currents of more than 50 kA _{rms} (tested by the German VDE)
– Max. prospective short-circuit current	100 kA _{rms} (220 kA _{peak})
– Limitation / Extinction of mains follow currents	up to 100 kA _{rms} (220 kA _{peak})
– Max. backup fuse (L) up to $I_k = 100$ kA _{rms}	315 A gL/gG
Weight	962 g
Customs tariff number	85363030
GTIN	4013364108141
PU	1 pc(s)

DEHNventil

DV M TT 255 (951 310)

- Prewired spark-gap-based type 1 and type 2 combined lightning current and surge arrester consisting of a base part and plug-in protection modules
- Maximum system availability due to RADAX Flow follow current limitation
- Capable of protecting terminal equipment



Figure without obligation

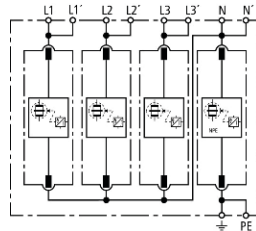

Basic circuit diagram DV M TT 255

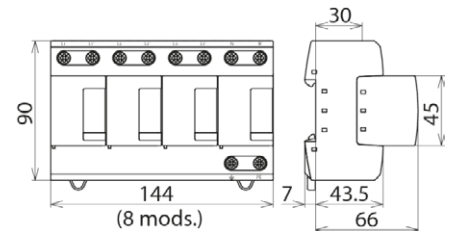

Dimension drawing DV M TT 255

Modular combined lightning current and surge arrester for TT and TN-S systems ("3+1" circuit).

Type Part No.	DV M TT 255 951 310
SPD according to EN 61643-11 / IEC 61643-11	type 1 + type 2 / class I + class II
Energy coordination with terminal equipment (≤ 5 m)	type 1 + type 2 + type 3
Nominal a.c. voltage (U_N)	230 / 400 V (50 / 60 Hz)
Max. continuous operating a.c. voltage [L-N] (U_C)	264 V (50 / 60 Hz)
Max. continuous operating a.c. voltage [N-PE] ($U_{C(N-PE)}$)	255 V (50 / 60 Hz)
Lightning impulse current (10/350 μ s) [L1+L2+L3+N-PE] (I_{total})	100 kA
Specific energy [L1+L2+L3+N-PE] (W/R)	2.50 MJ/ohms
Lightning impulse current (10/350 μ s) [L-N]/[N-PE] (I_{imp})	25 / 100 kA
Specific energy [L-N]/[N-PE] (W/R)	156.25 kJ/ohms / 2.50 MJ/ohms
Nominal discharge current (8/20 μ s) [L-N]/[N-PE] (I_n)	25 / 100 kA
Voltage protection level [L-N]/[N-PE] (U_p)	≤ 1.5 / ≤ 1.5 kV
Follow current extinguishing capability [L-N]/[N-PE] (I_{fr})	50 kA _{rms} / 100 A _{rms}
Follow current limitation / Selectivity	no tripping of a 20 A gL/gG fuse up to 50 kA _{rms} (prosp.)
Response time (t_A)	≤ 100 ns
Max. backup fuse (L) up to $I_k = 50$ kA _{rms}	315 A gG
Max. backup fuse (L-L')	125 A gG
Temporary overvoltage (TOV) [L-N] (U_T) – Characteristic	440 V / 120 min. – withstand
Temporary overvoltage (TOV) [N-PE] (U_T) – Characteristic	1200 V / 200 ms – withstand
Operating temperature range [parallel] / [series] (T_U)	-40 °C ... +80 °C / -40 °C ... +60 °C
Operating state / fault indication	green / red
Number of ports	1
Cross-sectional area (L1, L1', L2, L2', L3, L3', N, N', PE, \ominus) (min.)	10 mm ² solid / flexible
Cross-sectional area (L1, L2, L3, N, PE) (max.)	50 mm ² stranded / 35 mm ² flexible
Cross-sectional area (L1', L2', L3', N', \ominus) (max.)	35 mm ² stranded / 25 mm ² flexible
For mounting on	35 mm DIN rails acc. to EN 60715
Enclosure material	thermoplastic, red, UL 94 V-0
Place of installation	indoor installation
Degree of protection	IP 20
Capacity	8 module(s), DIN 43880
Approvals	KEMA, VDE, UL, VdS
Extended technical data:	Use in switchgear installations with prospective short-circuit currents of more than 50 kA _{rms} (tested by the German VDE)
– Max. prospective short-circuit current	100 kA _{rms} (220 kA _{peak})
– Limitation / Extinction of mains follow currents	up to 100 kA _{rms} (220 kA _{peak})
– Max. backup fuse (L) up to $I_k = 100$ kA _{rms}	315 A gL/gG
Weight	1,27 kg
Customs tariff number	85363030
GTIN	4013364108172
PU	1 pc(s)

DEHNventil

DV M TT 255 FM (951 315)

- Prewired spark-gap-based type 1 and type 2 combined lightning current and surge arrester consisting of a base part and plug-in protection modules
- Maximum system availability due to RADAX Flow follow current limitation
- Capable of protecting terminal equipment



Figure without obligation

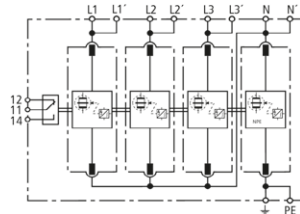

Basic circuit diagram DV M TT 255 FM

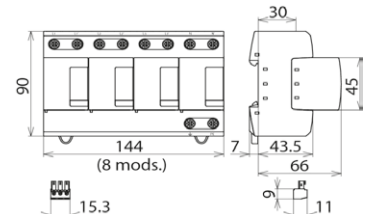

Dimension drawing DV M TT 255 FM

Modular combined lightning current and surge arrester for TT and TN-S systems ("3+1" circuit).

Type	DV M TT 255 FM
Part No.	951 315
SPD according to EN 61643-11 / IEC 61643-11	type 1 + type 2 / class I + class II
Energy coordination with terminal equipment (≤ 5 m)	type 1 + type 2 + type 3
Nominal a.c. voltage (U_N)	230 / 400 V (50 / 60 Hz)
Max. continuous operating a.c. voltage [L-N] (U_C)	264 V (50 / 60 Hz)
Max. continuous operating a.c. voltage [N-PE] ($U_{C(N-PE)}$)	255 V (50 / 60 Hz)
Lightning impulse current (10/350 μ s) [L1+L2+L3+N-PE] (I_{total})	100 kA
Specific energy [L1+L2+L3+N-PE] (W/R)	2.50 MJ/ohms
Lightning impulse current (10/350 μ s) [L-N]/[N-PE] (I_{imp})	25 / 100 kA
Specific energy [L-N]/[N-PE] (W/R)	156.25 kJ/ohms / 2.50 MJ/ohms
Nominal discharge current (8/20 μ s) [L-N]/[N-PE] (I_n)	25 / 100 kA
Voltage protection level [L-N]/[N-PE] (U_p)	≤ 1.5 / ≤ 1.5 kV
Follow current extinguishing capability [L-N]/[N-PE] (I_t)	50 kA _{rms} / 100 A _{rms}
Follow current limitation / Selectivity	no tripping of a 20 A gL/gG fuse up to 50 kA _{rms} (prosp.)
Response time (t_A)	≤ 100 ns
Max. backup fuse (L) up to $I_k = 50$ kA _{rms}	315 A gG
Max. backup fuse (L-L')	125 A gG
Temporary overvoltage (TOV) [L-N] (U_T) – Characteristic	440 V / 120 min. – withstand
Temporary overvoltage (TOV) [N-PE] (U_T) – Characteristic	1200 V / 200 ms – withstand
Operating temperature range [parallel] / [series] (T_U)	-40 °C ... +80 °C / -40 °C ... +60 °C
Operating state / fault indication	green / red
Number of ports	1
Cross-sectional area (L1, L1', L2, L2', L3, L3', N, N', PE, \pm) (min.)	10 mm ² solid / flexible
Cross-sectional area (L1, L2, L3, N, PE) (max.)	50 mm ² stranded / 35 mm ² flexible
Cross-sectional area (L1', L2', L3', N', \pm) (max.)	35 mm ² stranded / 25 mm ² flexible
For mounting on	35 mm DIN rails acc. to EN 60715
Enclosure material	thermoplastic, red, UL 94 V-0
Place of installation	indoor installation
Degree of protection	IP 20
Capacity	8 module(s), DIN 43880
Approvals	KEMA, VDE, UL, VdS
Type of remote signalling contact	changeover contact
a.c. switching capacity	250 V / 0.5 A
d.c. switching capacity	250 V / 0.1 A; 125 V / 0.2 A; 75 V / 0.5 A
Cross-sectional area for remote signalling terminals	max. 1.5 mm ² solid / flexible
Extended technical data:	Use in switchgear installations with prospective short-circuit currents of more than 50 kA _{rms} (tested by the German VDE)
– Max. prospective short-circuit current	100 kA _{rms} (220 kA _{peak})
– Limitation / Extinction of mains follow currents	up to 100 kA _{rms} (220 kA _{peak})
– Max. backup fuse (L) up to $I_k = 100$ kA _{rms}	315 A gL/gG
Weight	1,28 kg
Customs tariff number	85363030
GTIN	4013364108189
PU	1 pc(s)

DEHNguard

DG M TT 2P 275 (952 110)

- Prewired complete unit consisting of a base part and plug-in protection modules
- High discharge capacity due to heavy-duty zinc oxide varistors / spark gaps
- High reliability due to "Thermo Dynamic Control" SPD monitoring device



Figure without obligation

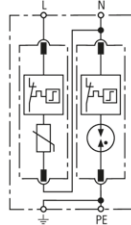

Basic circuit diagram DG M TT 2P 275

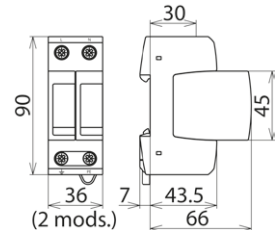

Dimension drawing DG M TT 2P 275

Modular surge arrester for use in single-phase TT and TN systems ("1+1" circuit).

Type	DG M TT 2P 275
Part No.	952 110
SPD according to EN 61643-11 / IEC 61643-11	type 2 / class II
Nominal a.c. voltage (U_N)	230 V (50 / 60 Hz)
Max. continuous operating a.c. voltage [L-N] (U_C)	275 V (50 / 60 Hz)
Max. continuous operating a.c. voltage [N-PE] (U_C)	255 V (50 / 60 Hz)
Nominal discharge current (8/20 μ s) (I_n)	20 kA
Max. discharge current (8/20 μ s) (I_{max})	40 kA
Lightning impulse current (10/350 μ s) [N-PE] (I_{imp})	12 kA
Voltage protection level [L-N] (U_P)	≤ 1.5 kV
Voltage protection level [L-N] at 5 kA (U_P)	≤ 1 kV
Voltage protection level [N-PE] (U_P)	≤ 1.5 kV
Follow current extinguishing capability [N-PE] (I_n)	100 A _{rms}
Response time [L-N] (t_A)	≤ 25 ns
Response time [N-PE] (t_A)	≤ 100 ns
Max. mains-side overcurrent protection	125 A gG
Short-circuit withstand capability for max. mains-side overcurrent protection (I_{SCCR})	50 kA _{rms}
Temporary overvoltage (TOV) [L-N] (U_T) – Characteristic	335 V / 5 sec. – withstand
Temporary overvoltage (TOV) [L-N] (U_T) – Characteristic	440 V / 120 min. – safe failure
Temporary overvoltage (TOV) [N-PE] (U_T) – Characteristic	1200 V / 200 ms – withstand
Operating temperature range (T_U)	-40 °C ... +80 °C
Operating state / fault indication	green / red
Number of ports	1
Cross-sectional area (min.)	1.5 mm ² solid / flexible
Cross-sectional area (max.)	35 mm ² stranded / 25 mm ² flexible
For mounting on	35 mm DIN rails acc. to EN 60715
Enclosure material	thermoplastic, red, UL 94 V-0
Place of installation	indoor installation
Degree of protection	IP 20
Capacity	2 module(s), DIN 43880
Approvals	KEMA, VDE, UL, VdS
Weight	242 g
Customs tariff number	85363030
GTIN	4013364108417
PU	1 pc(s)

DEHNguard

DG M TT 2P 275 FM (952 115)

- Prewired complete unit consisting of a base part and plug-in protection modules
- High discharge capacity due to heavy-duty zinc oxide varistors / spark gaps
- High reliability due to "Thermo Dynamic Control" SPD monitoring device



Figure without obligation

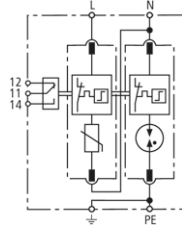

Basic circuit diagram DG M TT 2P 275 FM

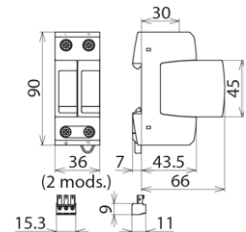

Dimension drawing DG M TT 2P 275 FM

Modular surge arrester for single-phase TT and TN systems ("1+1" circuit); with floating remote signalling contact.

Type	DG M TT 2P 275 FM
Part No.	952 115
SPD according to EN 61643-11 / IEC 61643-11	type 2 / class II
Nominal a.c. voltage (U_N)	230 V (50 / 60 Hz)
Max. continuous operating a.c. voltage [L-N] (U_C)	275 V (50 / 60 Hz)
Max. continuous operating a.c. voltage [N-PE] (U_C)	255 V (50 / 60 Hz)
Nominal discharge current (8/20 μ s) (I_n)	20 kA
Max. discharge current (8/20 μ s) (I_{max})	40 kA
Lightning impulse current (10/350 μ s) [N-PE] (I_{imp})	12 kA
Voltage protection level [L-N] (U_P)	≤ 1.5 kV
Voltage protection level [L-N] at 5 kA (U_P)	≤ 1 kV
Voltage protection level [N-PE] (U_P)	≤ 1.5 kV
Follow current extinguishing capability [N-PE] (I_n)	100 A _{rms}
Response time [L-N] (t_A)	≤ 25 ns
Response time [N-PE] (t_A)	≤ 100 ns
Max. mains-side overcurrent protection	125 A gG
Short-circuit withstand capability for max. mains-side overcurrent protection (I_{SCCR})	50 kA _{rms}
Temporary overvoltage (TOV) [L-N] (U_T) – Characteristic	335 V / 5 sec. – withstand
Temporary overvoltage (TOV) [L-N] (U_T) – Characteristic	440 V / 120 min. – safe failure
Temporary overvoltage (TOV) [N-PE] (U_T) – Characteristic	1200 V / 200 ms – withstand
Operating temperature range (T_U)	-40 °C ... +80 °C
Operating state / fault indication	green / red
Number of ports	1
Cross-sectional area (min.)	1.5 mm ² solid / flexible
Cross-sectional area (max.)	35 mm ² stranded / 25 mm ² flexible
For mounting on	35 mm DIN rails acc. to EN 60715
Enclosure material	thermoplastic, red, UL 94 V-0
Place of installation	indoor installation
Degree of protection	IP 20
Capacity	2 module(s), DIN 43880
Approvals	KEMA, VDE, UL, VdS
Type of remote signalling contact	changeover contact
a.c. switching capacity	250 V / 0.5 A
d.c. switching capacity	250 V / 0.1 A; 125 V / 0.2 A; 75 V / 0.5 A
Cross-sectional area for remote signalling terminals	max. 1.5 mm ² solid / flexible
Weight	228 g
Customs tariff number	85363030
GTIN	4013364108424
PU	1 pc(s)

DEHNguard

DG M TN 275 (952 200)

- Prewired complete unit consisting of a base part and plug-in protection modules
- High discharge capacity due to heavy-duty zinc oxide varistors / spark gaps
- High reliability due to "Thermo Dynamic Control" SPD monitoring device



Figure without obligation

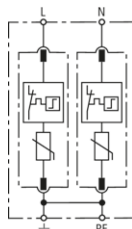

Basic circuit diagram DG M TN 275

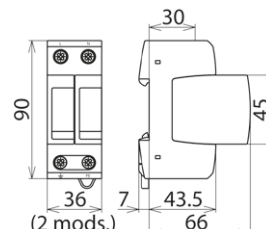

Dimension drawing DG M TN 275

Modular surge arrester for use in single-phase TN systems.

Type	DG M TN 275
Part No.	952 200
SPD according to EN 61643-11 / IEC 61643-11	type 2 / class II
Nominal a.c. voltage (U_N)	230 V (50 / 60 Hz)
Max. continuous operating a.c. voltage (U_C)	275 V (50 / 60 Hz)
Nominal discharge current (8/20 μ s) (I_n)	20 kA
Max. discharge current (8/20 μ s) (I_{max})	40 kA
Voltage protection level (U_P)	≤ 1.5 kV
Voltage protection level at 5 kA (U_P)	≤ 1 kV
Response time (t_A)	≤ 25 ns
Max. mains-side overcurrent protection	125 A gG
Short-circuit withstand capability for max. mains-side overcurrent protection (I_{SCCR})	50 kA _{rms}
Temporary overvoltage (TOV) (U_T) – Characteristic	335 V / 5 sec. – withstand
Temporary overvoltage (TOV) (U_T) – Characteristic	440 V / 120 min. – safe failure
Operating temperature range (T_U)	-40 °C ... +80 °C
Operating state / fault indication	green / red
Number of ports	1
Cross-sectional area (min.)	1.5 mm ² solid / flexible
Cross-sectional area (max.)	35 mm ² stranded / 25 mm ² flexible
For mounting on	35 mm DIN rails acc. to EN 60715
Enclosure material	thermoplastic, red, UL 94 V-0
Place of installation	indoor installation
Degree of protection	IP 20
Capacity	2 module(s), DIN 43880
Approvals	KEMA, VDE, UL, VdS
Weight	229 g
Customs tariff number	85363030
GTIN	4013364108394
PU	1 pc(s)

DEHNguard

DG M TN 275 FM (952 205)

- Prewired complete unit consisting of a base part and plug-in protection modules
- High discharge capacity due to heavy-duty zinc oxide varistors / spark gaps
- High reliability due to "Thermo Dynamic Control" SPD monitoring device



Figure without obligation

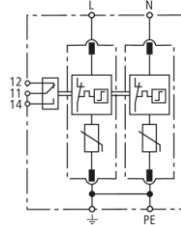

Basic circuit diagram DG M TN 275 FM

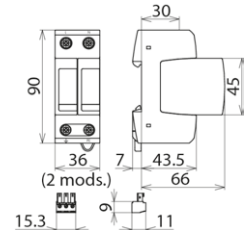

Dimension drawing DG M TN 275 FM

Modular surge arrester for use in single-phase TN systems; with floating remote signalling contact.

Type	DG M TN 275 FM
Part No.	952 205
SPD according to EN 61643-11 / IEC 61643-11	type 2 / class II
Nominal a.c. voltage (U_N)	230 V (50 / 60 Hz)
Max. continuous operating a.c. voltage (U_C)	275 V (50 / 60 Hz)
Nominal discharge current (8/20 μ s) (I_n)	20 kA
Max. discharge current (8/20 μ s) (I_{max})	40 kA
Voltage protection level (U_P)	≤ 1.5 kV
Voltage protection level at 5 kA (U_P)	≤ 1 kV
Response time (t_A)	≤ 25 ns
Max. mains-side overcurrent protection	125 A gG
Short-circuit withstand capability for max. mains-side overcurrent protection (I_{SCCR})	50 kA _{rms}
Temporary overvoltage (TOV) (U_T) – Characteristic	335 V / 5 sec. – withstand
Temporary overvoltage (TOV) (U_T) – Characteristic	440 V / 120 min. – safe failure
Operating temperature range (T_U)	-40 °C ... +80 °C
Operating state / fault indication	green / red
Number of ports	1
Cross-sectional area (min.)	1.5 mm ² solid / flexible
Cross-sectional area (max.)	35 mm ² stranded / 25 mm ² flexible
For mounting on	35 mm DIN rails acc. to EN 60715
Enclosure material	thermoplastic, red, UL 94 V-0
Place of installation	indoor installation
Degree of protection	IP 20
Capacity	2 module(s), DIN 43880
Approvals	KEMA, VDE, UL, VdS
Type of remote signalling contact	changeover contact
a.c. switching capacity	250 V / 0.5 A
d.c. switching capacity	250 V / 0.1 A; 125 V / 0.2 A; 75 V / 0.5 A
Cross-sectional area for remote signalling terminals	max. 1.5 mm ² solid / flexible
Weight	232 g
Customs tariff number	85363030
GTIN	4013364108400
PU	1 pc(s)

BLITZDUCTOR XT

BXT ML2 BE S 24 (920 224)

- LifeCheck SPD monitoring function
- Optimal protection of two single lines and the cable shield
- For use in conformity with the lightning protection zone concept at the boundaries from $0_A -2$ and higher



Figure without obligation

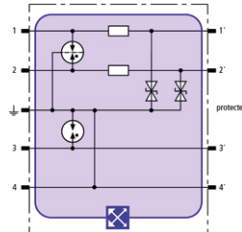

Basic circuit diagram BXT ML2 BE S 24

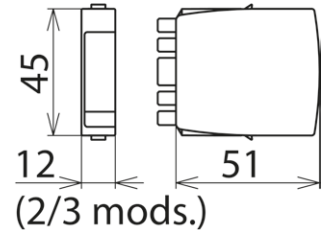

Dimension drawing BXT ML2 BE S 24

Space-saving combined lightning current and surge arrester module with LifeCheck feature for protecting two single lines sharing a common reference potential as well as unbalanced interfaces, with direct or indirect shield earthing. If LifeCheck detects thermal or electrical overload, the arrester has to be replaced. This status is indicated contactlessly by the DEHNrecord LC / SCM / MCM reader.

Type	BXT ML2 BE S 24
Part No.	920 224
SPD monitoring system	LifeCheck
SPD class	TYPE 1 PI
Nominal voltage (U_N)	24 V
Max. continuous operating d.c. voltage (U_c)	33 V
Max. continuous operating a.c. voltage (U_c)	23.3 V
Nominal current at 45 °C (I_L)	0.75 A
D1 Total lightning impulse current (10/350 μ s) (I_{imp})	9 kA
D1 Lightning impulse current (10/350 μ s) per line (I_{imp})	2.5 kA
C2 Total nominal discharge current (8/20 μ s) (I_n)	20 kA
C2 Nominal discharge current (8/20 μ s) per line (I_n)	10 kA
Voltage protection level line-line for I_{imp} D1 (U_p)	≤ 102 V
Voltage protection level line-PG for I_{imp} D1 (U_p)	≤ 66 V
Voltage protection level line-line at 1 kV/ μ s C3 (U_p)	≤ 90 V
Voltage protection level line-PG at 1 kV/ μ s C3 (U_p)	≤ 45 V
Series resistance per line	1.8 ohm(s)
Cut-off frequency line-PG (f_c)	6.8 MHz
Capacitance line-line (C)	≤ 0.5 nF
Capacitance line-PG (C)	≤ 1.0 nF
Operating temperature range (T_U)	-40 °C ... +80 °C
Degree of protection (plugged-in)	IP 20
Pluggable into	BXT BAS / BSP BAS 4 base part
Earthing via	BXT BAS / BSP BAS 4 base part
Enclosure material	polyamide PA 6.6
Colour	yellow
Test standards	IEC 61643-21 / EN 61643-21, UL 497B
SIL classification	up to SIL3 ^{*)}
ATEX approvals	DEKRA 11ATEX0089 X: II 3 G Ex nA IIC T4 Gc
IECEx approvals	DEK 11.0032X: Ex nA IIC T4 Gc
CSA & USA Hazloc approvals (1)	2516389: Class I Div. 2 GP A, B, C, D T4
CSA & USA Hazloc approvals (2)	2516389: Class I Zone 2, AEx nA IIC T4
Approvals	CSA, GOST, VdS
Weight	37 g
Customs tariff number	85363010
GTIN	4013364117785
PU	1 pc(s)

^{*)}For more detailed information, please visit www.dehn-international.com.

BLITZDUCTOR XT

BXT ML2 BD 180 (920 247)

- LifeCheck SPD monitoring function
- Optimal protection of one pair
- For installation in conformity with the lightning protection zone concept at the boundaries from 0_A-2 and higher



Figure without obligation

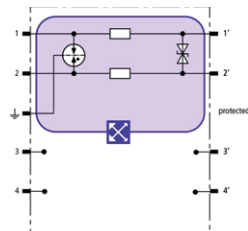

Basic circuit diagram BXT ML2 BD 180

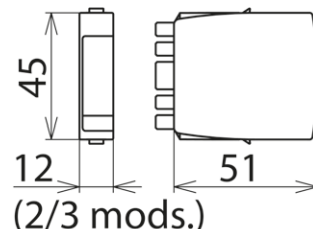

Dimension drawing BXT ML2 BD 180

Space-saving combined lightning current and surge arrester module with LifeCheck feature for protecting one pair of unearthed balanced interfaces. If LifeCheck detects thermal or electrical overload, the arrester has to be replaced. This status is indicated contactlessly by the DEHNrecord LC / SCM / MCM reader.

Type	BXT ML2 BD 180
Part No.	920 247
SPD monitoring system	LifeCheck
SPD class	TYPE 1P2
Nominal voltage (U_N)	180 V
Max. continuous operating d.c. voltage (U_c)	180 V
Max. continuous operating a.c. voltage (U_c)	127 V
Nominal current at 45 °C (I_L)	0.75 A
D1 Total lightning impulse current (10/350 μ s) (I_{imp})	5 kA
D1 Lightning impulse current (10/350 μ s) per line (I_{imp})	2.5 kA
C2 Total nominal discharge current (8/20 μ s) (I_n)	20 kA
C2 Nominal discharge current (8/20 μ s) per line (I_n)	10 kA
Voltage protection level line-line for I_{imp} D1 (U_p)	≤ 270 V
Voltage protection level line-PG for I_{imp} D1 (U_p)	≤ 550 V
Voltage protection level line-line at 1 kV/ μ s C3 (U_p)	≤ 250 V
Voltage protection level line-PG at 1 kV/ μ s C3 (U_p)	≤ 550 V
Series resistance per line	1.8 ohm(s)
Cut-off frequency line-line (f_c)	25.0 MHz
Capacitance line-line (C)	≤ 240 pF
Capacitance line-PG (C)	≤ 16 pF
Operating temperature range (T_U)	-40 °C ... +80 °C
Degree of protection (plugged-in)	IP 20
Pluggable into	BXT BAS / BSP BAS 4 base part
Earthing via	BXT BAS / BSP BAS 4 base part
Enclosure material	polyamide PA 6.6
Colour	yellow
Test standards	IEC 61643-21 / EN 61643-21, UL 497B
SIL classification	up to SIL3 ^{*)}
ATEX approvals	DEKRA 11ATEX0089 X: II 3 G Ex nA IIC T4 Gc
IECEx approvals	DEK 11.0032X: Ex nA IIC T4 Gc
CSA & USA Hazloc approvals (1)	2516389: Class I Div. 2 GP A, B, C, D T4
CSA & USA Hazloc approvals (2)	2516389: Class I Zone 2, AEx nA IIC T4
Approvals	CSA, GOST, VdS
Weight	43 g
Customs tariff number	85363010
GTIN	4013364116078
PU	1 pc(s)

^{*)} For more detailed information, please visit www.dehn-international.com.

BLITZDUCTOR XT

BXT ML2 BD HFS 5 (920 271)

- LifeCheck SPD monitoring function
- Minimal signal interference
- For installation in conformity with the lightning protection zone concept at the boundaries from $0_A -2$ and higher



Figure without obligation

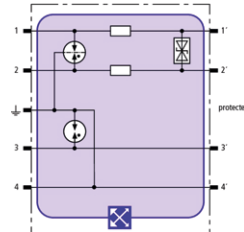

Basic circuit diagram BXT ML2 BD HFS

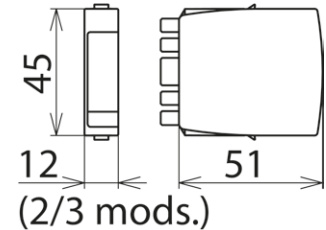

Dimension drawing BXT ML2 BD HFS

Space-saving combined lightning current and surge arrester module with LifeCheck feature for protecting one pair of unearthed high-frequency bus systems or video transmission systems, with direct or indirect shield earthing. If LifeCheck detects thermal or electrical overload, the arrester has to be replaced. This status is indicated contactlessly by the DEHNrecord LC / SCM / MCM reader.

Type	BXT ML2 BD HFS 5
Part No.	920 271
SPD monitoring system	LifeCheck
SPD class	TYPE 1 PI
Nominal voltage (U_N)	5 V
Max. continuous operating d.c. voltage (U_c)	6.0 V
Max. continuous operating a.c. voltage (U_c)	4.2 V
Nominal current at 45 °C (I_L)	1.0 A
D1 Total lightning impulse current (10/350 μ s) (I_{imp})	9 kA
D1 Lightning impulse current (10/350 μ s) per line (I_{imp})	2.5 kA
C2 Total nominal discharge current (8/20 μ s) (I_n)	20 kA
C2 Nominal discharge current (8/20 μ s) per line (I_n)	10 kA
Voltage protection level line-line for I_{imp} D1 (U_p)	≤ 25 V
Voltage protection level line-PG for I_{imp} D1 (U_p)	≤ 550 V
Voltage protection level line-line at 1 kV/ μ s C3 (U_p)	≤ 11 V
Voltage protection level line-PG at 1 kV/ μ s C3 (U_p)	≤ 550 V
Series resistance per line	1.0 ohm(s)
Cut-off frequency line-line (f_c)	100.0 MHz
Capacitance line-line (C)	≤ 25 pF
Capacitance line-PG (C)	≤ 25 pF
Operating temperature range (T_U)	-40 °C ... +80 °C
Degree of protection (plugged-in)	IP 20
Pluggable into	BXT BAS / BSP BAS 4 base part
Earthing via	BXT BAS / BSP BAS 4 base part
Enclosure material	polyamide PA 6.6
Colour	yellow
Test standards	IEC 61643-21 / EN 61643-21, UL 497B
SIL classification	up to SIL3 ^{*)}
ATEX approvals	DEKRA 11ATEX0089 X: II 3 G Ex nA IIC T4 Gc
IECEx approvals	DEK 11.0032X: Ex nA IIC T4 Gc
CSA & USA Hazloc approvals (1)	2516389: Class I Div. 2 GP A, B, C, D T4
CSA & USA Hazloc approvals (2)	2516389: Class I Zone 2, AEx nA IIC T4
Approvals	CSA, UL, GOST, VdS
Weight	22 g
Customs tariff number	85363010
GTIN	4013364117556
PU	1 pc(s)

^{*)} For more detailed information, please visit www.dehn-international.com.

BLITZDUCTOR XT

BXT ML4 BE 24 (920 324)

- LifeCheck SPD monitoring function
- Optimal protection of four single lines
- For installation in conformity with the lightning protection zone concept at the boundaries from $0_A - 2$ and higher



Figure without obligation

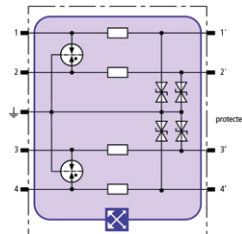

Basic circuit diagram BXT ML4 BE 24

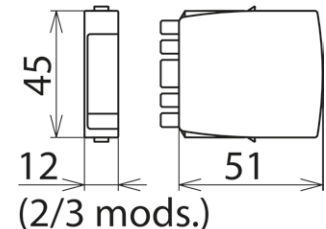

Dimension drawing BXT ML4 BE 24

Space-saving combined lightning current and surge arrester module with LifeCheck feature for protecting four single lines sharing a common reference potential as well as unbalanced interfaces. If LifeCheck detects thermal or electrical overload, the arrester has to be replaced. This status is indicated contactlessly by the DEHNrecord LC / SCM / MCM reader.

Type	BXT ML4 BE 24
Part No.	920 324
SPD monitoring system	LifeCheck
SPD class	TYPE 1 PI
Nominal voltage (U_N)	24 V
Max. continuous operating d.c. voltage (U_c)	33 V
Max. continuous operating a.c. voltage (U_c)	23.3 V
Nominal current at 45 °C (I_L)	0.75 A
D1 Total lightning impulse current (10/350 μ s) (I_{imp})	10 kA
D1 Lightning impulse current (10/350 μ s) per line (I_{imp})	2.5 kA
C2 Total nominal discharge current (8/20 μ s) (I_n)	20 kA
C2 Nominal discharge current (8/20 μ s) per line (I_n)	10 kA
Voltage protection level line-line for I_{imp} D1 (U_p)	≤ 102 V
Voltage protection level line-PG for I_{imp} D1 (U_p)	≤ 66 V
Voltage protection level line-line at 1 kV/ μ s C3 (U_p)	≤ 90 V
Voltage protection level line-PG at 1 kV/ μ s C3 (U_p)	≤ 45 V
Series resistance per line	1.8 ohm(s)
Cut-off frequency line-PG (f_c)	6.8 MHz
Capacitance line-line (C)	≤ 0.5 nF
Capacitance line-PG (C)	≤ 1.0 nF
Operating temperature range (T_U)	-40 °C ... +80 °C
Degree of protection (plugged-in)	IP 20
Pluggable into	BXT BAS / BSP BAS 4 base part
Earthing via	BXT BAS / BSP BAS 4 base part
Enclosure material	polyamide PA 6.6
Colour	yellow
Test standards	IEC 61643-21 / EN 61643-21, UL 497B
SIL classification	up to SIL3 ^{*)}
ATEX approvals	DEKRA 11ATEX0089 X: II 3 G Ex nA IIC T4 Gc
IECEx approvals	DEK 11.0032X: Ex nA IIC T4 Gc
CSA & USA Hazloc approvals (1)	2516389: Class I Div. 2 GP A, B, C, D T4
CSA & USA Hazloc approvals (2)	2516389: Class I Zone 2, AEx nA IIC T4
Approvals	CSA, VdS, UL, GOST
Weight	38 g
Customs tariff number	85363010
GTIN	4013364109056
PU	1 pc(s)

^{*)} For more detailed information, please visit www.dehn-international.com.

BLITZDUCTOR XT

BXT ML4 BD 180 (920 347)

- LifeCheck SPD monitoring function
- Optimal protection of two pairs
- For installation in conformity with the lightning protection zone concept at the boundaries from $0_A -2$ and higher



Figure without obligation

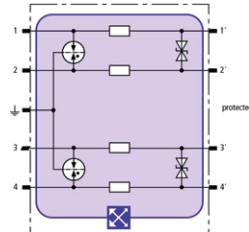

Basic circuit diagram BXT ML4 BD 180

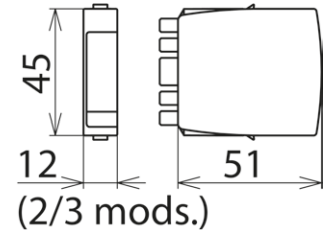

Dimension drawing BXT ML4 BD 180

Space-saving combined lightning current and surge arrester module with LifeCheck feature for protecting two pairs of unearthed balanced interfaces. If LifeCheck detects thermal or electrical overload, the arrester has to be replaced. This status is indicated contactlessly by the DEHNrecord LC / SCM / MCM reader.

Type	BXT ML4 BD 180
Part No.	920 347
SPD monitoring system	LifeCheck
SPD class	TYPE 1P2
Nominal voltage (U_N)	180 V
Max. continuous operating d.c. voltage (U_c)	180 V
Max. continuous operating a.c. voltage (U_c)	127 V
Nominal current at 45 °C (I_L)	0.75 A
D1 Total lightning impulse current (10/350 μ s) (I_{imp})	10 kA
D1 Lightning impulse current (10/350 μ s) per line (I_{imp})	2.5 kA
C2 Total nominal discharge current (8/20 μ s) (I_n)	20 kA
C2 Nominal discharge current (8/20 μ s) per line (I_n)	10 kA
Voltage protection level line-line for I_{imp} D1 (U_p)	≤ 270 V
Voltage protection level line-PG for I_{imp} D1 (U_p)	≤ 550 V
Voltage protection level line-line at 1 kV/ μ s C3 (U_p)	≤ 250 V
Voltage protection level line-PG at 1 kV/ μ s C3 (U_p)	≤ 550 V
Series resistance per line	1.8 ohm(s)
Cut-off frequency line-line (f_c)	25.0 MHz
Capacitance line-line (C)	≤ 240 pF
Capacitance line-PG (C)	≤ 16 pF
Operating temperature range (T_U)	-40 °C ... +80 °C
Degree of protection (plugged-in)	IP 20
Pluggable into	BXT BAS / BSP BAS 4 base part
Earthing via	BXT BAS / BSP BAS 4 base part
Enclosure material	polyamide PA 6.6
Colour	yellow
Test standards	IEC 61643-21 / EN 61643-21, UL 497B
SIL classification	up to SIL3 ^{*)}
ATEX approvals	DEKRA 11ATEX0089 X: II 3 G Ex nA IIC T4 Gc
IECEx approvals	DEK 11.0032X: Ex nA IIC T4 Gc
CSA & USA Hazloc approvals (1)	2516389: Class I Div. 2 GP A, B, C, D T4
CSA & USA Hazloc approvals (2)	2516389: Class I Zone 2, AEx nA IIC T4
Approvals	CSA, VdS, UL, GOST
Weight	24 g
Customs tariff number	85363010
GTIN	4013364109018
PU	1 pc(s)

^{*)}For more detailed information, please visit www.dehn-international.com.

BLITZDUCTOR XT

BXT ML2 BD S EX 24 (920 280)

- For universal use, with LifeCheck monitoring function
- Self-capacitance and self-inductance negligibly small
- For installation in conformity with the lightning protection zone concept at the boundaries from $0_B - 2$ and higher



Figure without obligation

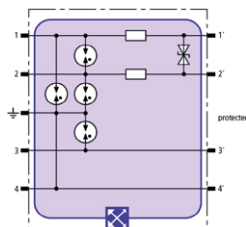

Basic circuit diagram BXT ML2 BD S EX 24

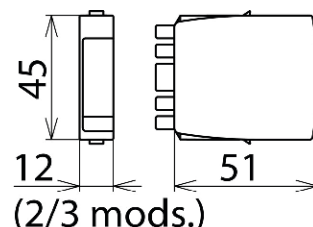

Dimension drawing BXT ML2 BD S EX 24

Space-saving surge arrester module with LifeCheck feature for protecting one pair of intrinsically safe measuring circuits and bus systems, direct or indirect shield earthing. Insulation strength > 500 V line-earth.

If LifeCheck detects thermal or electrical overload, the arrester has to be replaced. This status is indicated contactlessly by DEHNrecord LC / SCM / MCM.

Type	BXT ML2 BD S EX 24
Part No.	920 280
SPD class	TYPE 2PI
SPD monitoring	LifeCheck
Nominal voltage (U_N)	24 V
Max. continuous operating d.c. voltage (U_c)	33 V
Max. continuous operating a.c. voltage (U_c)	23.3 V
Max. input voltage acc. to EN 60079-11 (U_i)	30 V
Max. input current acc. to EN 60079-11 (I_i)	0.5 A
D1 Total lightning impulse current (10/350 μ s) (I_{imp})	4 kA
D1 Lightning impulse current (10/350 μ s) per line (I_{imp})	1 kA
C2 Total nominal discharge current (8/20 μ s) (I_n)	10 kA
C2 Nominal discharge current (8/20 μ s) per line (I_n)	5 kA
Voltage protection level line-line for I_{imp} D1 (U_p)	≤ 50 V
Voltage protection level line-PG for I_{imp} D1 (U_p)	≤ 1300 V
Voltage protection level line-line for I_n C2 (U_p)	≤ 52 V
Voltage protection level line-PG for I_n C2 (U_p)	≤ 1400 V
Voltage protection level line-line at 1 kV/ μ s C3 (U_p)	≤ 45 V
Voltage protection level line-PG at 1 kV/ μ s C3 (U_p)	≤ 1100 V
Series resistance per line	1.0 ohm
Cut-off frequency line-line (f_c)	6 MHz
Capacitance line-line (C)	≤ 1.0 nF
Capacitance line-PG (C)	≤ 16 pF
Operating temperature range (T_U)	-40 °C ... +80 °C
Degree of protection (plugged-in)	IP 20
Plugs into	base part
Earthing via	base part
Enclosure material	polyamide PA 6.6
Colour	blue
Test standards	IEC 61643-21 / EN 61643-21
ATEX approvals (1)	KEMA 06ATEX0274 X: II 2 (1) G Ex ia [ia Ga] IIC T4 ... T6 Gb
ATEX approvals (2)	KEMA 06ATEX0274 X: II 2 G Ex ib IIC T4 ... T6 Gb
IECEx approvals (1)	DEK 11.0078X: Ex ia [ia Ga] IIC T4 ... T6 Gb
IECEx approvals (2)	DEK 11.0078X: Ex ib IIC T4 ... T6 Gb
CSA & USA Hazloc approvals (1)	70000011: Class I Div. 1; Class I Zone 1
CSA & USA Hazloc approvals (2)	70000011: Ex ia [ia] IIC T4 ... T6
Approvals	GOST
Weight	22 g
Customs tariff number	85363010
GTIN	4013364142138
PU	1 pc(s)

BLITZDUCTOR XT

BXT ML4 BD EX 24 (920 381)

- For universal use, with LifeCheck monitoring function
- Self-capacitance and self-inductance negligibly small
- For installation in conformity with the lightning protection zone concept at the boundaries from 0_B-2 and higher



Figure without obligation

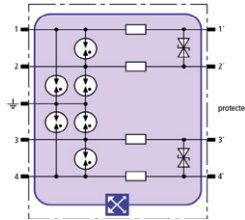

Basic circuit diagram BXT ML4 BD EX 24

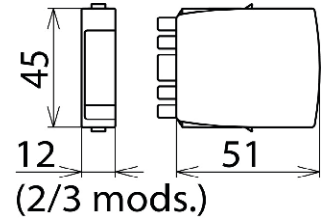

Dimension drawing BXT ML4 BD EX 24

Space-saving surge arrester module with LifeCheck feature for protecting two pairs of intrinsically safe measuring circuits and bus systems, meets FISCO requirements. ATEX. Insulation strength > 500 V line-earth.

If LifeCheck detects thermal or electrical overload, the arrester has to be replaced. This status is indicated contactlessly by DEHNrecord LC / SCM / MCM.

Type	BXT ML4 BD EX 24
Part No.	920 381
SPD class	TYPE 2 Pt
SPD monitoring	LifeCheck
Nominal voltage (U_N)	24 V
Max. continuous operating d.c. voltage (U_c)	33 V
Max. continuous operating a.c. voltage (U_e)	23 V
Max. input voltage acc. to EN 60079-11 (U_i)	30 V
Max. input current acc. to EN 60079-11 (I_i)	0.5 A
D1 Total lightning impulse current (10/350 μ s) (I_{imp})	4 kA
D1 Lightning impulse current (10/350 μ s) per line (I_{imp})	1 kA
C2 Total nominal discharge current (8/20 μ s) (I_n)	20 kA
C2 Nominal discharge current (8/20 μ s) per line (I_n)	5 kA
Voltage protection level line-line for I_{imp} D1 (U_p)	≤ 50 V
Voltage protection level line-PG for I_{imp} D1 (U_p)	≤ 1300 V
Voltage protection level line-line for I_n C2 (U_p)	≤ 52 V
Voltage protection level line-PG for I_n C2 (U_p)	≤ 1400 V
Voltage protection level line-line at 1 kV/ μ s C3 (U_p)	≤ 45 V
Voltage protection level line-PG at 1 kV/ μ s C3 (U_p)	≤ 1100 V
Series resistance per line	1.0 ohm
Cut-off frequency line-line (f_c)	7.7 MHz
Capacitance line-line (C)	≤ 0.8 nF
Capacitance line-PG (C)	≤ 16 pF
Operating temperature range (T_u)	-40 °C ... +80 °C
Degree of protection (plugged-in)	IP 20
Plugs into	base part
Earthing via	base part
Enclosure material	polyamide PA 6.6
Colour	blue
Test standards	IEC 61643-21 / EN 61643-21, UL 497B
SIL classification	up to SIL3 ^{*)}
ATEX approvals (1)	KEMA 06ATEX0274 X: II 2 (1) G Ex ia [ia Ga] IIC T4 ... T6 Gb
ATEX approvals (2)	KEMA 06ATEX0274 X: II 2 G Ex ib IIC T4 ... T6 Gb
IECEx approvals (1)	DEK 11.0078X: Ex ia [ia Ga] IIC T4 ... T6 Gb
IECEx approvals (2)	DEK 11.0078X: Ex ib IIC T4 ... T6 Gb
CSA & USA Hazloc approvals (1)	70000011: Class I Div. 1; Class I Zone 1
CSA & USA Hazloc approvals (2)	70000011: Ex ia [ia] IIC T4 ... T6
Approvals	CSA, GOST
Weight	23 g
Customs tariff number	85363010
GTIN	4013364109025
PU	1 pc(s)

^{*)} For more detailed information, please visit www.dehn-international.com.

BLITZDUCTOR XT

BXT BAS (920 300)

- Four-pole version for universal use with all types of BSP and BXT / BXTU protection modules
- No signal interruption if the protection module is removed
- Universal design without protection elements



Figure without obligation

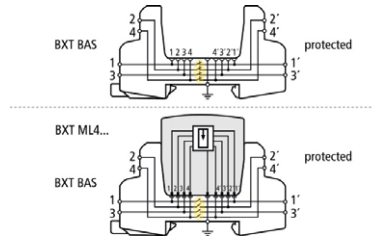

Basic circuit diagram with and without plugged-in module

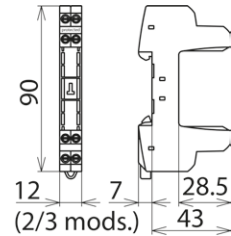

Dimension drawing BXT BAS

The BLITZDUCTOR XT base part is a very space-saving and universal four-pole feed-through terminal for the insertion of a protection module without signal interruption if the protection module is removed. The snap-in mechanism at the supporting foot of the base part allows the protection module to be safely earthed via the DIN rail. Since no components of the protective circuit are situated in the base part, only the protection modules must be maintained.

Type Part No.	BXT BAS 920 300
Operating temperature range (T _U)	-40 °C ... +80 °C
Degree of protection	IP 20
For mounting on	35 mm DIN rails acc. to EN 60715
Connection (input / output)	screw / screw
Signal disconnection	no
Cross-sectional area, solid	0.08-4 mm ²
Cross-sectional area, flexible	0.08-2.5 mm ²
Tightening torque (terminals)	0.4 Nm
Earthing via	35 mm DIN rails acc. to EN 60715
Enclosure material	polyamide PA 6.6
Colour	yellow
ATEX approvals	DEKRA 11ATEX0089 X: II 3 G Ex nA IIC T4 Gc ^{*)}
IECEx approvals	DEK 11.0032X: Ex nA IIC T4 Gc ^{*)}
Approvals	CSA, VdS, UL, GOST
Weight	34 g
Customs tariff number	85369010
GTIN	4013364109179
PU	1 pc(s)

^{*)} only in connection with an approved protection module

BLITZDUCTOR XT

BXT BAS EX (920 301)

- Four-pole and universal base part for all types of intrinsically safe protection modules
- No signal interruption if the protection module is removed
- Universal design without protection elements



Figure without obligation

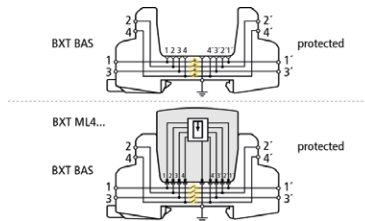

Basic circuit diagram with and without module

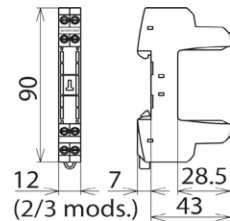

Dimension drawing BXT BAS EX

BLITZDUCTOR XT base part for use as an extremely space-saving and universal four-pole feed-through terminal for intrinsically safe circuits for the insertion of the protection module, no signal disconnection if the protection module is removed. The snap-in mechanism at the supporting foot of the base part allows the device to be safely earthed via the DIN rail. Since no components of the protective circuit are situated in the base part, only the protection modules must be maintained.

Type	BXT BAS EX
Part No.	920 301
Operating temperature range	-40 °C ... +80 °C
Degree of protection	IP 20
For mounting on	35 mm DINs rails acc. to EN 60715
Connection (input / output)	screw / screw
Cross-sectional area, solid	0.08-4 mm ²
Cross-sectional area, flexible	0.08-2.5 mm ²
Tightening torque (terminals)	0.4 Nm
Earthing via	35 mm DIN rails acc. to EN 60715
Enclosure material	polyamide PA 6.6
Colour	blue
ATEX approvals (1)	KEMA 06ATEX0274 X: II 2 (1) G Ex ia [ia Ga] IIC T4 ... T6 Gb *)
ATEX approvals (2)	KEMA 06ATEX0274 X: II 2 G Ex ib IIC T4 ... T6, Gb *)
IECEx approvals (1)	DEK 11.0078X: Ex ia [ia Ga] IIC T4 ... T6 Gb *)
IECEx approvals (2)	DEK 11.0078X: Ex ib IIC T4 ... T6 Gb *)
CSA & USA Hazloc approvals (1)	70000011: Class I Div. 1; Class I Zone 1
CSA & USA Hazloc approvals (2)	70000011: Ex ia [ia] IIC T4 ... T6
Approvals	UL, CSA, GOST
Weight	53 g
Customs tariff number	85369010
GTIN	4013364109186
PU	1 pc(s)

*) only in connection with an approved protection module

www.dehn-international.com/partners



**Surge Protection
Lightning Protection
Safety Equipment
DEHN protects.**

DEHN + SÖHNE
GmbH + Co.KG.

Hans-Dehn-Str. 1
Postfach 1640
92306 Neumarkt
Germany

Tel. +49 9181 906-0
Fax +49 9181 906-1100
info@dehn.de
www.dehn-international.com



www.dehn-international.com/partners

Type designations of products mentioned in the white paper being at the same time registered trademarks are not especially marked. So if there is no marking of TM or © this does not mean that the type designation is a free trade name. Neither it can be seen whether patents or utility models and other intellectual and industrial property rights are available. We reserve the right to introduce changes in performance, configuration and technology, dimensions, weights and materials in the course of technical progress. The figures are shown without obligation. Misprints, errors and modifications excepted. Reproduction in any form whatsoever is forbidden without our authorisation.

actiVsense, BLITZDUCTOR, BLITZPLANER, DEHN, DEHN Logo, DEHN schützt, DEHNbloc, DEHNfix, DEHNgrip, DEHNguard, DEHNport, DEHNQUICK, DEHNrapid, DEHNshield, DEHNSnap, DEHNventil, HVI, LifeCheck, Red/Line are protected by German Trade Mark, by Community Trade Mark (EU) and/or in other countries.